

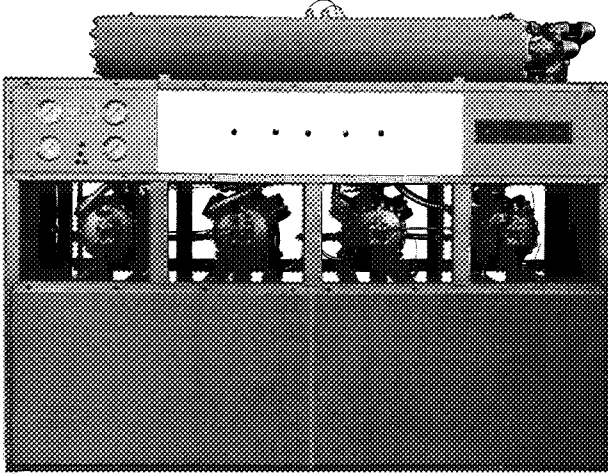

30HH,HJ

**Installation and
Maintenance Instructions**

30HH-6



Codes C and MA (533011)

**30HH,HJ
HERMETIC RECIPROCATING
LIQUID CHILLING PACKAGE**

30HH501055

4-64

Tab

15

Supersedes 30HH501045

12-62



CONTENTS

	PAGE
INSTALLATION SECTION	
Dimension Drawings	3-5
Preliminary Survey	6
Moving and Placing Unit	6-7
Unit Specifications	7-10
Compressor Physical Data	7
Condenser Physical Data	8
Cooler Physical Data	9
Refrigerant Circuits	10
Refrigerant Charge	10
Compressor Mounting	10
Condenser Water Piping	11-13
Cooler Water Piping	14
Refrigerant Piping	15-16
Leak Testing	17
Dehydrate the System	17-18
Start-up Procedures	18-20
Charge with Refrigerant	20-21
Oil Charge	21
Check the Controls	21-23
Starters and Overloads	23
Circuit Breakers	23-24
Water Regulating Valve	24
Temperature Controller Adjustment	24-26
Wiring Diagrams	27-32
Electrical Data	33-34
Capacity Controls	34-35
Sequence of Operation	35-36
Moisture and Liquid Indicator	37
MAINTENANCE SECTION	
Condenser Maintenance	38-39
Trouble Diagnosis Chart	40-42
Compressor Maintenance	42
Cause and Prevention of Freeze-up	42

30HH-200-11

NOTES:

- CONDENSER AND ATTACHED PIPING AS SHOWN ARE FOR 30HH MODEL ONLY.
- REMOVABLE PANELS FURNISHED ON UNIT AS FOLLOWS: ONE PANEL EACH SIDE, PANELS FRONT AND BACK OF COOLER SECTION, PANELS OVER FRONT OF COMPR., STEP CONT. AND CONTROL CENTER SECTIONS.
- SIDE PANELS PROVIDED WITH HOLES FOR CHILLED WATER PIPING.
- TWO HOLES PROVIDED IN REAR PANEL OF CONTROL BOX FOR CONTROL AND AUXILIARY WIRE ACCESS.
- CONTROL BULB OF TEMPERATURE CONTROLLER TO BE FIELD INSTALLED IN INLET CHILLED WATER LINE.
- STANDARD CONTROL VOLTAGE IS 230 VOLTS FOR 208, 230 & 400 VOLT UNITS. FOR 460 & 575 VOLT UNITS STANDARD CONTROL VOLTAGE IS 115 VOLTS.

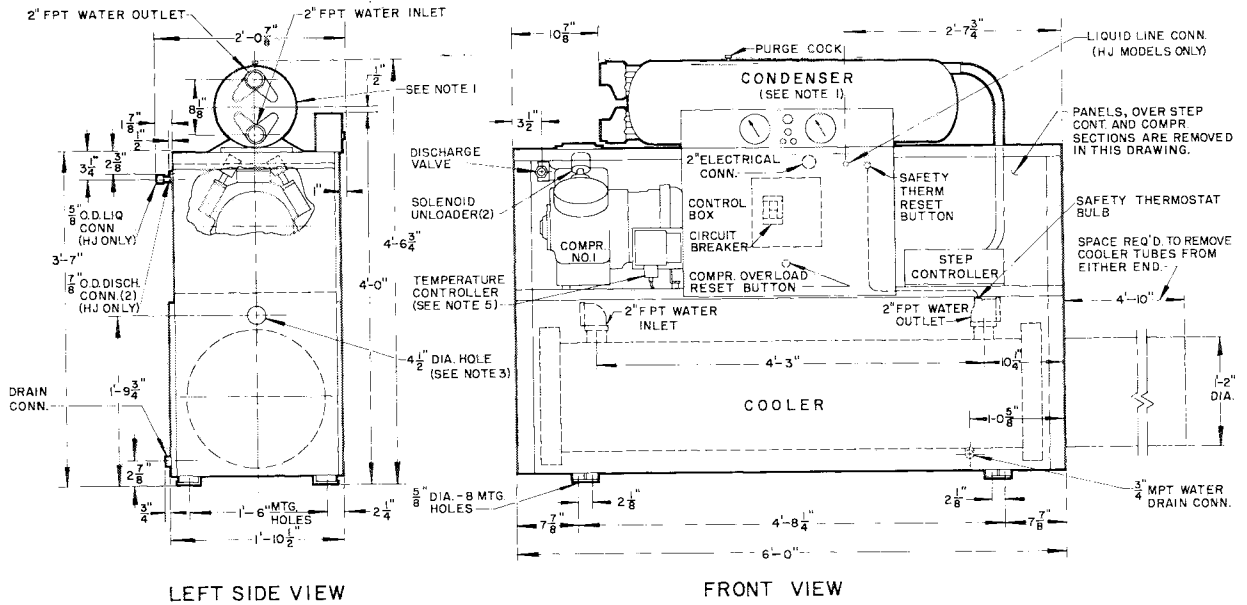

Fig. 1 - 30HH,HJ015 Dimensional Data

30HH-200-12

NOTES:

- CONDENSER AND ATTACHED PIPING AS SHOWN ARE FOR 30HH MODEL ONLY.
- REMOVABLE PANELS FURNISHED ON UNIT AS FOLLOWS: ONE PANEL EACH SIDE, PANELS FRONT AND BACK OF COOLER SECTION, PANELS OVER FRONT OF COMPR., STEP CONT. AND CONTROL CENTER SECTIONS.
- SIDE PANELS PROVIDED WITH HOLES FOR CHILLED WATER PIPING.
- TWO HOLES PROVIDED IN REAR PANEL OF CONTROL BOX FOR CONTROL AND AUXILIARY WIRE ACCESS.
- CONTROL BULB OF TEMPERATURE CONTROLLER TO BE FIELD INSTALLED IN INLET CHILLED WATER LINE.
- STANDARD CONTROL VOLTAGE IS 230 VOLTS FOR 208, 230 & 400 VOLT UNITS. FOR 460 & 575 VOLT UNITS STANDARD CONTROL VOLTAGE IS 115 VOLTS.

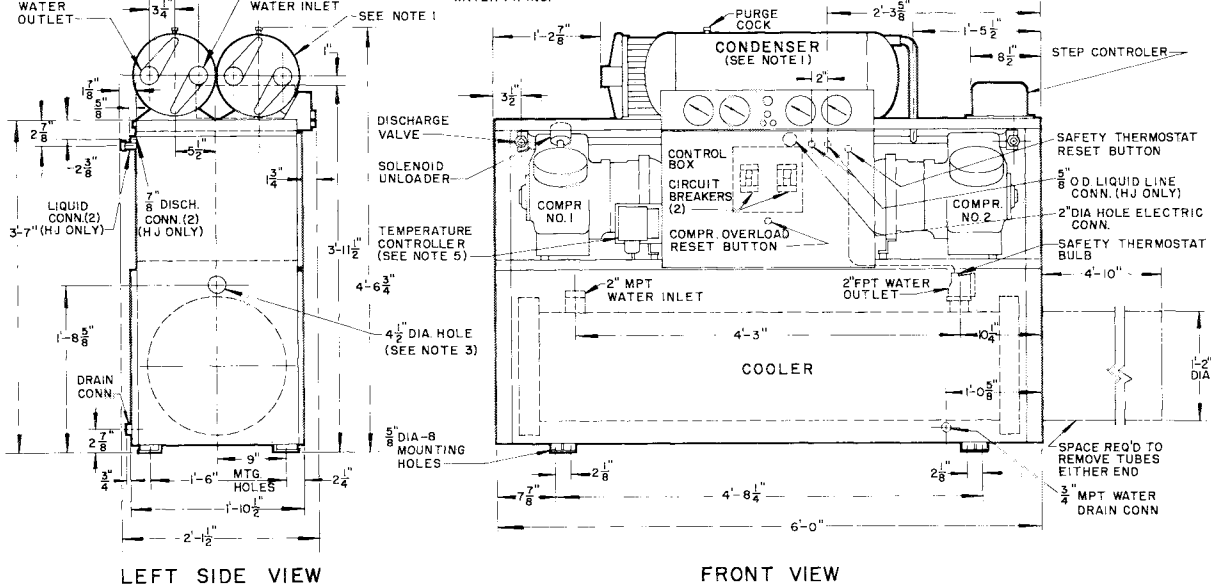

Fig. 2 - 30HH,HJ020 Dimensional Data

30HH,HJ

INSTALLATION

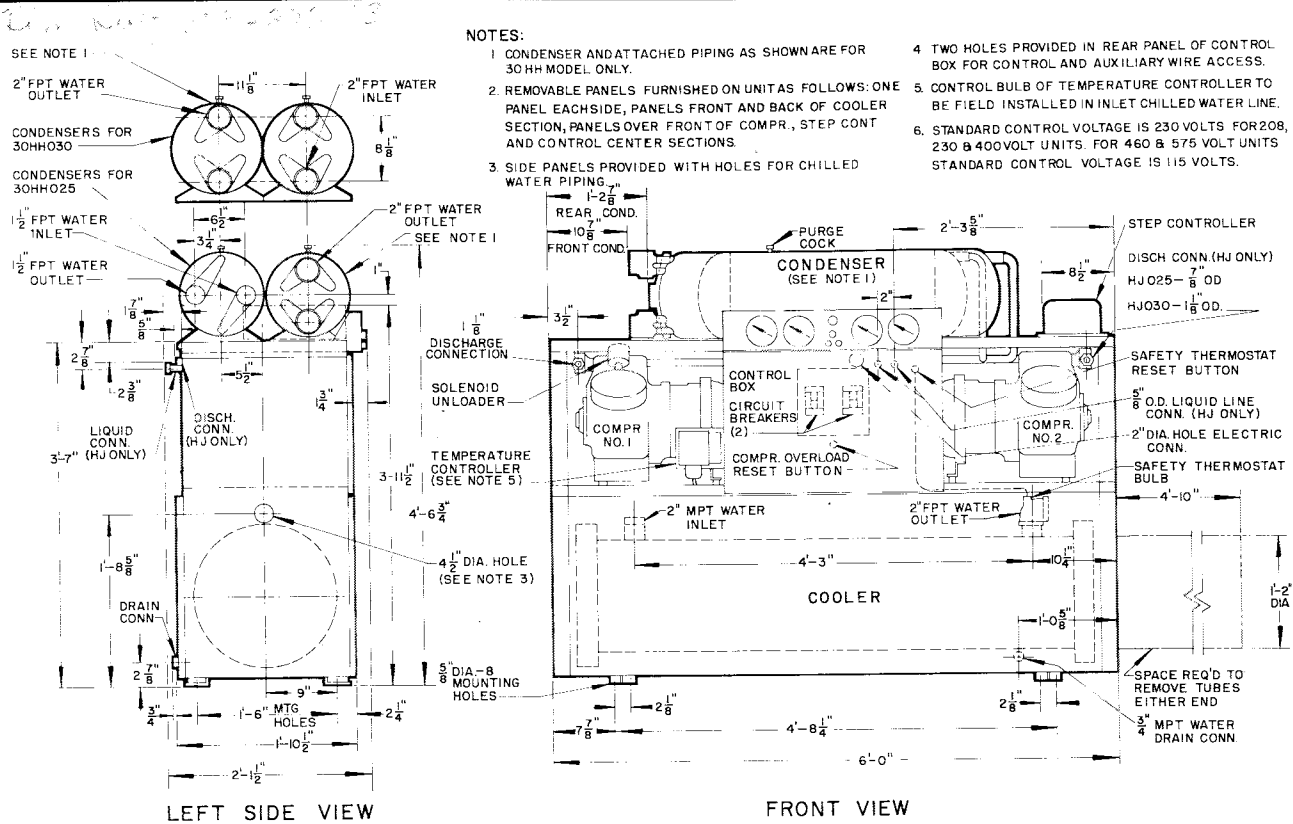

Fig. 3 - 30HH,HJ025,030 Dimensional Data

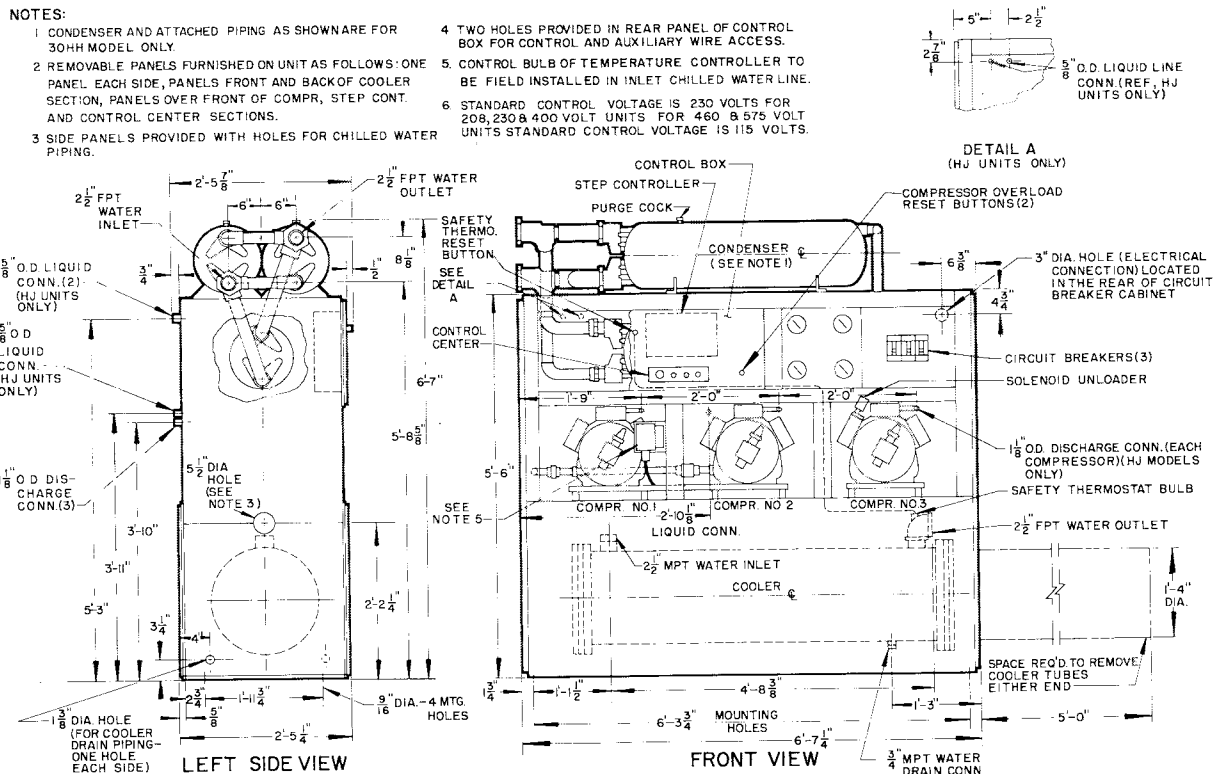

Fig. 4 - 30HH,HJ045 Dimensional Data

NOTES:

1. REMOVABLE PANELS FURNISHED ON UNIT AS FOLLOWS: ONE PANEL EACH SIDE, PANELS FRONT AND BACK OF COOLER SECTION, PANELS OVER FRONT OF COMPR., STEP CONT. AND CONTROL CENTER SECTIONS.
2. SIDE PANELS PROVIDED WITH HOLES FOR CHILLED WATER PIPING

3. TWO HOLES PROVIDED IN REAR PANEL OF CONTROL BOX FOR CONTROL AND AUXILIARY WIRE ACCESS.
4. CONTROL BULB OF TEMPERATURE CONTROLLER TO BE FIELD INSTALLED IN INLET CHILLED WATER LINE.
5. STANDARD CONTROL VOLTAGE IS 230 VOLTS FOR 208, 230 & 400 VOLT UNITS. FOR 460 & 575 VOLT UNITS STANDARD CONTROL VOLTAGE IS 115 VOLTS.

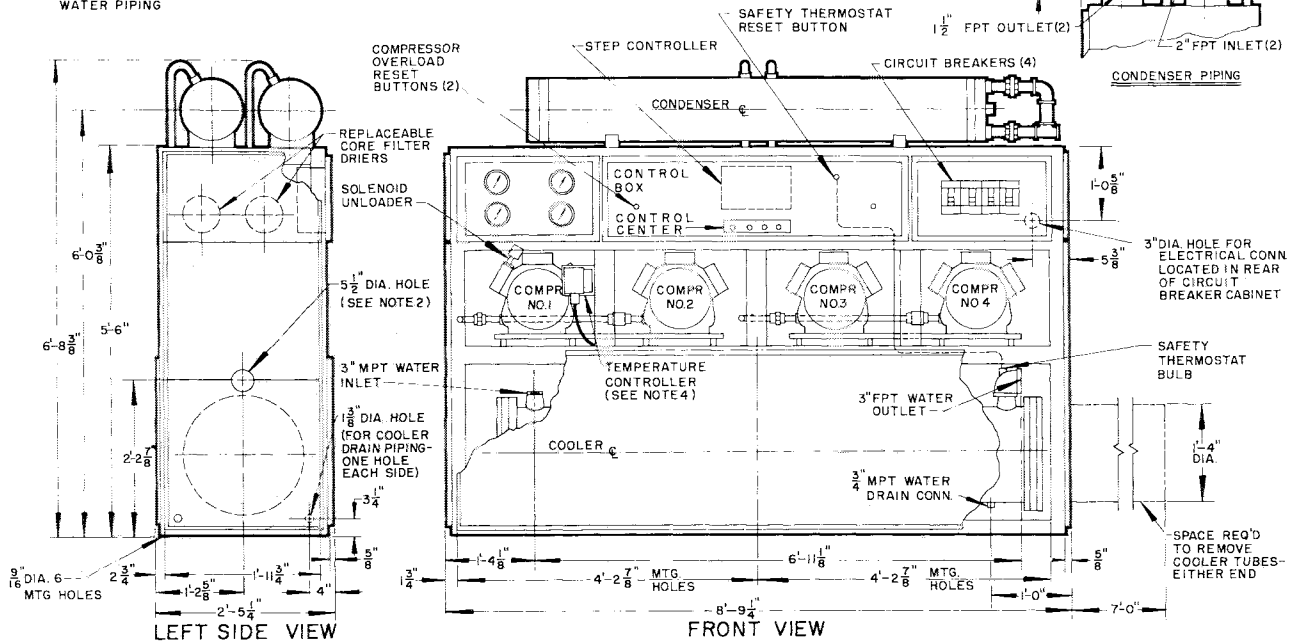

Fig. 5 - 30HH055 Dimensional Data

NOTES:

1. CONDENSER AND ATTACHED PIPING AS SHOWN ARE FOR 30HH MODEL ONLY.
2. REMOVABLE PANELS FURNISHED ON UNIT AS FOLLOWS: ONE PANEL EACH SIDE, PANELS FRONT AND BACK OF COOLER SECTION, PANELS OVER FRONT OF COMPR., STEP CONT. AND CONTROL CENTER SECTIONS.
3. SIDE PANELS PROVIDED WITH HOLES FOR CHILLED WATER PIPING.

4. TWO HOLES PROVIDED IN REAR PANEL OF CONTROL BOX FOR CONTROL AND AUXILIARY WIRE ACCESS.
5. CONTROL BULB OF TEMPERATURE CONTROLLER TO BE FIELD INSTALLED IN INLET CHILLED WATER LINE.
6. STANDARD CONTROL VOLTAGE IS 230 VOLTS FOR 208, 230 & 400 VOLT UNITS. FOR 460 & 575 VOLT UNITS STANDARD CONTROL VOLTAGE IS 115 VOLTS.

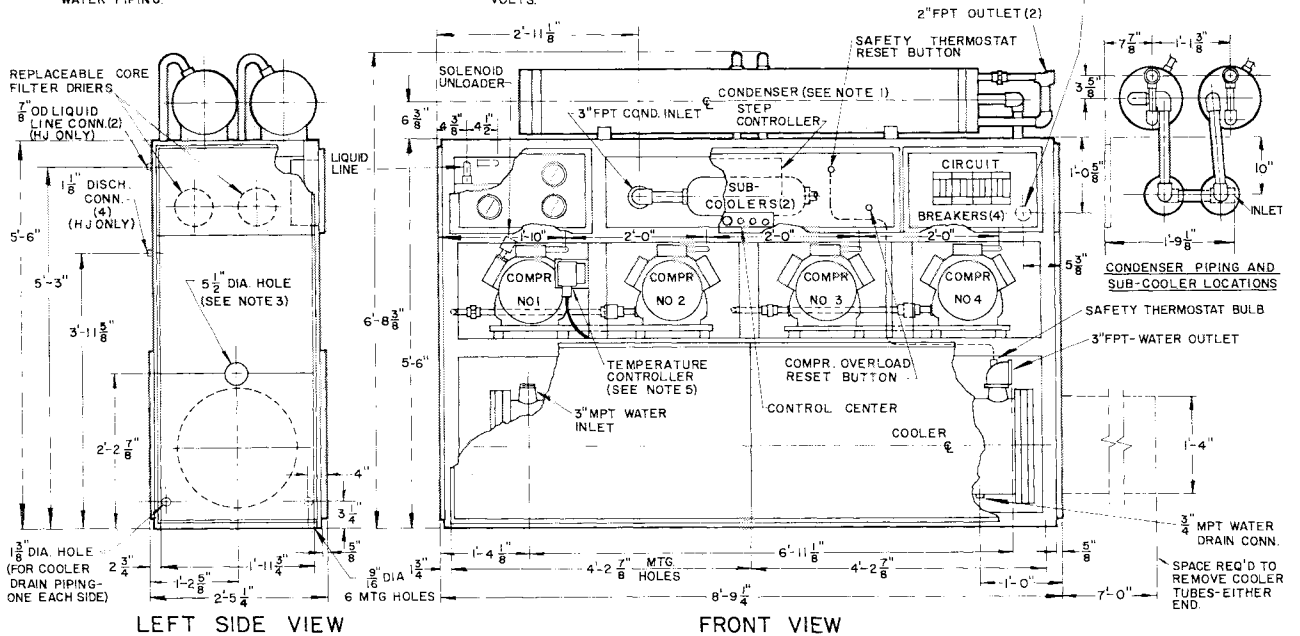

Fig. 6 - 30HH,HJ065 Dimensional Data

PRELIMINARY SURVEY

Before installation is started, a survey should be made to establish the procedures and materials required by installation personnel. See cover picture for typical unit.

Storage

Because of the sensitive control mechanisms and electrical devices incorporated in the 30HH,HJ units, they should not be exposed to the weather.

Location

Always locate the unit indoors. In order to prevent freezing, the unit must be located in a space where the temperature is at least 40 degrees.

Space Requirements and Clearance

Dimensions for the units are given in Table 1. These dimensions are useful in checking door clearances for moving the unit in and for determining space requirements. A clearance of 2 to 3 feet should be left on each side and on the ends for piping and electrical connections and also to facilitate service operations. Clearance at one end of the unit, equal to the length of the unit, for servicing and removal of chiller tubes must be provided.

Adequate Floor Strength

Approximate weights of units are given in Table 1. Make certain that the floor is strong enough to support this weight. If necessary, add supporting structure to the floor for transferring

weight to the nearest beams. This can be done with steel beams or reinforced concrete slabs.

Vibration Isolation

Rubber-in-shear vibration insulators and mufflers are installed on, or furnished with, the compressors of all units beginning with early 1961 production. The inter-connecting piping must be sufficiently flexible to prevent vibration transmission. If vibration still exists, vibration isolators may be used on the unit itself. The field-purchased vibration mountings should be placed under each corner of the package. The weight distribution of all packages except the 30HH015 and 30HJ015 is such that each corner mounting supports one fourth of the operating weight. The weight distribution of the 30HH015 and 30HJ015 units is 55-45 side to side and symmetrical front to back.

All phases of vibration isolation are fully described in Section 5X-1 of the Product Information book. Consult same for best results.

For additional information see "Compressor Mounting."

MOVING AND PLACING UNIT

Moving

The skids on which the unit is mounted should not be removed until the unit is at the final location. When handling the unit with a chain hoist, remove the panels so that they will not be damaged by the sling. Do not attach the sling to

Table 1 - Weight and Overall Dimensions - 30HH,HJ Liquid Chiller Package

Unit	Shipping Wt. (lbs.)	Operating Wt. (lbs.)	Uncrated Dimensions (Ins.)			Crated Dimensions (Ins.)		
			Length	Width	Height	Length	Width	Height
30HH015	1430	1625	72	22-1/2	54-3/4	76	30	63
30HH020	2200	2150	72	22-1/2	54-3/4	76	30	63
30HJ015	1270	1460	72	22-1/2	47	76	30	63
30HJ020	1700	1800	72	25-1/2	47	76	30	63
30HH025	2200	1950	72	22-1/2	54-3/4	76	30	63
30HH030	2550	1950	72	22-1/2	54-3/4	76	30	63
30HJ025	2100	1800	72	25-1/2	47	76	30	63
30HJ030	2150	1850	72	25-1/2	47	76	30	63
30HH045	3010	3391	79-1/4	29-1/4	79	83-1/2	33	84-7/8
30HJ045	2455	2835	79-1/4	29-1/4	66	83-1/2	33	84-7/8
30HH055	4622	5158	105-1/4	29-1/4	80-3/8	109-3/4	33	86-3/4
30HH065	4700	5236	105-1/4	29-1/4	80-3/8	109-3/4	33	86-3/4
30HJ065	3700	4236	105-1/4	29-1/4	66	109-3/4	33	86-3/4

pipng or equipment. Move the unit in an upright position, and let it down gently from the truck or rollers. On 30HH,HJ015-030 units the sling can be placed under the frame channels at the main support (Fig. 7). On 30HH,HJ045 thru 065 units, the sling can be placed under the skids.

Placing

To anchor the equipment:

1. Locate the hold down bolts as shown in the dimension drawings. The areas where the four corners will be located should be approximately level before the unit is placed.
2. Set the unit in place and level with a spirit level on the frame channels.
3. Bolt the unit to the floor. This is usually desirable for basement or ground floor installations that can transmit vibration to the ground without affecting the building structure.

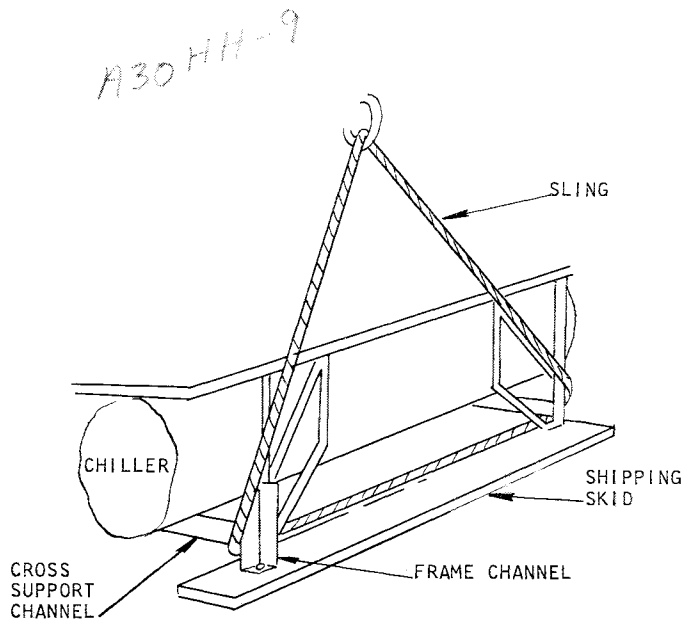

Fig. 7 - Rig Sling to Hoist Unit (015-030 Shown)

Table 2 - Compressor Motor Physical Data

Unit Size	30HH, HJ 015	30HH, HJ 020	30HH, HJ 025	30HH, HJ 030	30HH, HJ 045	30HH 055	30HH, HJ 065
Compressor Type	Hermetic Reciprocating						
Number	1	2	2	2	3	4	4
Sizes	1 - 6D73*	2 - 6D68	1 - 6D68 1 - 6D73*	2 - 6D73*	3 - 6D73*	1 - 6D68 3 - 6D73	4 - 6D73*
Cylinder (Total No.)	6	12	12	12	18	24	24
Speed - 60 Cycle (rpm)	1750	1750	1750	1750	1750	1750	1750
- 50 Cycle (rpm)	1460	1460	1460	1460	1460	1460	1460
Oil Charge (10 pt per compr) (pt)	10	20	20	20	30	40	40
Cylinder Unloading Devices (No.) †	2	1	1	1	1	1	1

*6D73 Compressors are used on the 30HH models only. 30HJ Models are supplied with 6D75 compressors.

† Each cylinder unloading device unloads two cylinders of the compressor when it is energized.

Table 3 - Condenser Physical Data

Unit Size		30HH015	30HH020	30HH025	30HH030	30HH045	30HH055	30HH065
Condensers (No.)		1	2	2	2	3	2	2
Condenser Type		Shell-and-Coil				Shell-and-Tube		
Tubes or Coils, each		6	4	1 - 6 1 - 4	6	6	64	64
Effective External Surface, each (sq ft)		82.7	53.9	1 - 53.9 1 - 82.7	82.7	82.7	165.7	165.7
Water Side Volume, each (gal)		3.5	2.5	1 - 2.5 1 - 3.5	3.5	3.5	5.0	5.0
Nominal Shell Diam (in.)		10-15/16	10-15/16	10-15/16	10-15/16	10-15/16	10-3/4	10-3/4
Shell Length (in.)		42-5/8	34-5/8	1 - 34-5/8 1 - 42-5/8	42-5/8	42-5/8	77	77
Water Connections (Total No.)		2	4	4	4	2	4	3
Water Connection Size (each cond.)	Inlet	1 - 2"	2 - 1-1/2"	1 - 1-1/2" 1 - 2"	2 - 2"	3 - 2"	2 - 2"	1 - 3"
	Outlet	1 - 2"	2 - 1-1/2"	1 - 1-1/2" 1 - 2"	2 - 2"	3 - 2"	2 - 1-1/2"	2 - 2"
Coil or Tube Type		Trufin				Trufin		
Coil or Tube OD (in.)		7/8				3/4		
Nominal Shell Thickness (in.)		.278				.307		
Materials of Construction	Shell	Steel				Steel		
	Coil or Tubes	Copper				Copper		
	Tube Sheet	Steel				Steel		
Max. Design Working Press. (psig)	Water Side	100				100		
	Refrig. Side	385				385		

NOTE: The 30HH065 unit is supplied with two subcoolers (one per circuit) to provide 15 F of subcooling.



INSTALLATION

30HH,HJ

Table 4 - Cooler Physical Data

Unit Size	30HH, HJ 015	30HH, HJ 020	30HH, HJ 025	30HH, HJ 030	30HH, HJ 045	30HH 055	30HH, HJ 065
Refrigerant Circuits (No.)	1	2	2	2	2	2	2
Tubes (No.)	136	136	136	136	188	186	186
Effective External Tube Surface (sq ft)	125	126	127	128	179	258	258
Length Between Tube Sheets (in.)	60-1/4	60-1/4	60-1/4	60-1/4	60-1/4	85-7/8	85-7/8
Shell Side Water Volume (gal)	20.4	20.6	20.8	21.0	26.6	38.2	38.2
Baffles (No.)	31	25	21	17	15	17	17
Baffle Spacing (in.)	1-7/16	1-27/32	2-7/32	2-3/4	3-1/4	4-1/2	4-1/2
Nominal Shell Diam. (in.)	14	14	14	14	16	16	16
Water Connection Size, IPS (in.)	2	2	2	2	2	3	3
Cooler Type	Direct Expansion						
Construction	Shell-and-Tube, Fixed Tubesheet						
Tube Type and Size (in.)	Prime Surface, 3/4 OD						
Nominal Shell Thickness (in.)	1/4						
Nominal Tube Sheet Thickness (in.)	1-3/8 Min.						
Materials of Construction	Shell	Steel					
	Tubes	Copper					
	Tube Sheet	Steel					
	Baffles	Polypropylene					
	Insulation	Closed Cell Foam Plastic, Vapor Sealed					
Maximum Design Working Press. (psig)	Water Side	250					
	Refrig. Side	150					

Table 5 - Refrigerant Circuits

Unit Size	Circuits	Description of Refrigerant Circuit	Capacity (%)
30HH, HJ015	1	(1) 6D73 or 6D75 Compr, Full Cooler Surface	100
30HH, HJ020	2	(1) 6D68 Compr, 1/2 Cooler Surface	50
		(1) 6D68 Compr, 1/2 Cooler Surface	50
30HH, HJ025	2	(1) 6D68 Compr, 1/2 Cooler Surface	40
		(1) 6D73 or 6D75 Compr, 1/2 Cooler Surface	60
30HH, HJ030	2	(1) 6D73 or 6D75 Compr, 1/2 Cooler Surface	50
		(1) 6D73 or 6D75 Compr, 1/2 Cooler Surface	50
30HH, HJ045	2	(1) 6D73 or 6D75 Compr, 1/3 Cooler Surface	33
		(2) 6D73 or 6D75 Compr, 2/3 Cooler Surface	67
30HH055	2	(2) 6D73 Compr, 1/2 Cooler Surface	55
		(1) 6D73 & (1) 6D68 Compr, 1/2 Cooler Surface	45
30HH, HJ065	2	(2) 6D73 or 6D75 Compr, 1/2 Cooler Surface	50
		(2) 6D73 or 6D75 Compr, 1/2 Cooler Surface	50

NOTE: 6D73 Compressors are used on 30HH models. 6D75 Compressors are used on 30HJ models.

Table 6 - Refrigerant Charge

Model 30HH, HJ	015	020	025	030	045	055	065
Refrigerant 22 (lb)	35	46	46	46	69	124	140

NOTES: 1. The refrigerant charges listed above do not include the additional charge required for remote condensers and piping with 30HJ models.

2. The 30HH015 and 30HH020 units are shipped fully charged with refrigerant. Other units are shipped with holding charges only.

COMPRESSOR MOUNTING

All 30HH,HJ chillers, as shipped, have the compressor rigidly mounted to the frame with bolts and steel pipe spacers. For proper operation, the following procedure should be followed:

30HH,HJ020 to 030 units (Fig. 8):

- Loosen the four (4) hold-down bolts on one compressor.
- Remove one hold-down bolt, lock washer and nut on oil pump end of compressor. Lift end of compressor and remove pipe spacer.
- Tighten hold-down bolt which is diagonally opposite spacer which was removed.
- Install 3/8-16 x 1-1/2" bolt, supplied in bag of fastenings, between compressor foot and bracket. Reinstall lock washer and nut.
- Loosen hold-down bolt tightened in step No. 3.
- Repeat steps 2 thru 5 for other oil pump end bolt.

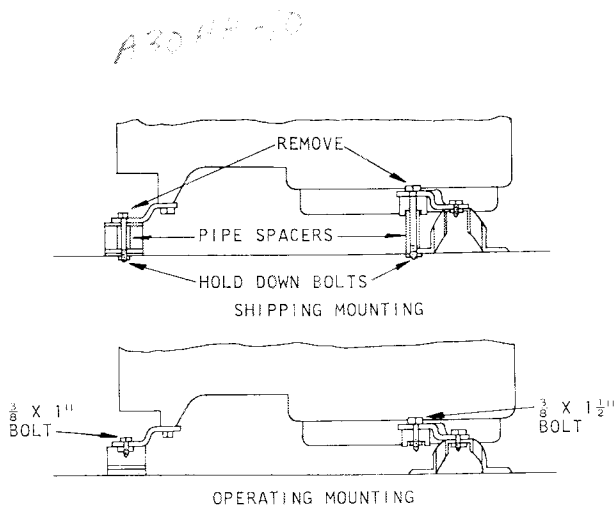

Fig. 8 - 30HH,HJ015-030 Compressor Mounting

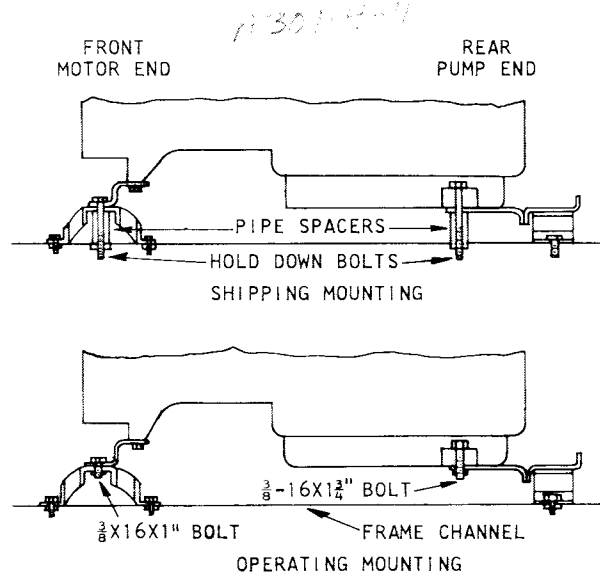

Fig. 9 - 30HH,HJ045-065 Compressor Mounting

7. Remove both compressor motor end hold-down bolts, nuts, lock washers, and pipe spacers, and replace with 3/8-16 x 1" bolts. Reinstall lock washers and nuts to fasten mounting brackets to resilient mounts.

6. Repeat steps 5 and 6 for the other motor end fastenings of the compressor.

30HH,HJ045 to 065 units (Fig. 9):

The pairs of manifolded compressors are mounted on common mounting brackets. Be sure all pipe spacers are removed for proper operation. The mounting of the single compressor on 30HH,HJ045 units is similar.

1. Remove one 3/8-16 x 3-1/2" hold-down bolt, nut, lock washer, and pipe spacer on the pump end of the compressor.
2. Install a 3/8-16 x 1-3/4" bolt, supplied in bag of fastenings, and reinstall nut and lock washer from hold-down bolt, to fasten compressor to mounting bracket.
3. Repeat steps 1 and 2 for the other pump end fastenings of the compressors.
4. Remove one 3/8-16 x 2-1/2" hold-down bolt, nut, lock washer and pipe spacer on the motor end of the compressor.
5. Install a 3/8-16 x 1" bolt, supplied in bag of fastenings, and reinstall nut and lock washer from hold-down bolt to fasten mounting bracket to resilient mount.

CONDENSER WATER PIPING

Water supply lines should be as short as conditions will permit. The size of these lines is not necessarily the same as those of the water valve connections. All piping must be sized in accordance with the pressure head available. This is especially true on cooling tower applications. See the System Design Manual, Part 3 - "Piping Design" for methods used in sizing pipe.

For installations using a waste water system, a separate water regulating valve is required for each refrigerant circuit. Water regulating valves are not supplied by Carrier.

NOTE: Provide means for draining the system in the winter and for repairs. Figure 10 thru 16 show suggested piping connections for each model when used with waste water or cooling towers.

Frangible Disc Safety Union

Each condenser is provided with a frangible disc that will relieve at 385 psig to protect the system from excessive pressure.

Some local codes require piping from the relief to the outdoors. The relief outlet size on both models is 3/8" male flare.

30HH,HJ

INSTALLATION



P30HH-12

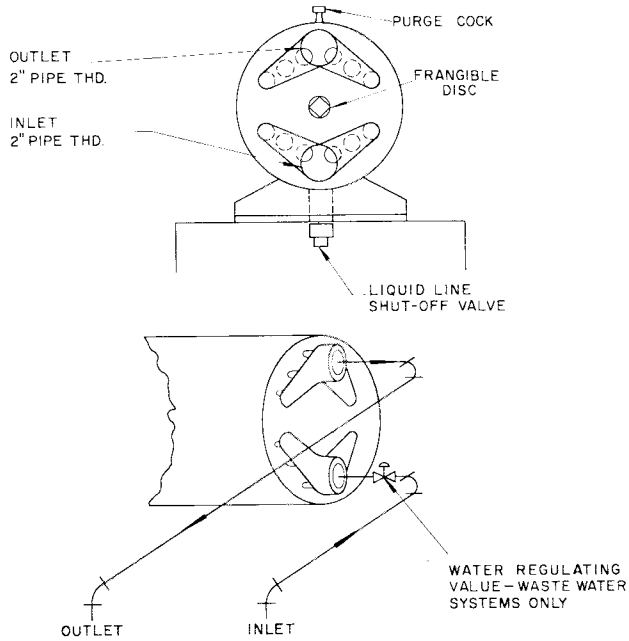

Fig. 10 - 30HH015 Condenser Piping

030HH-13

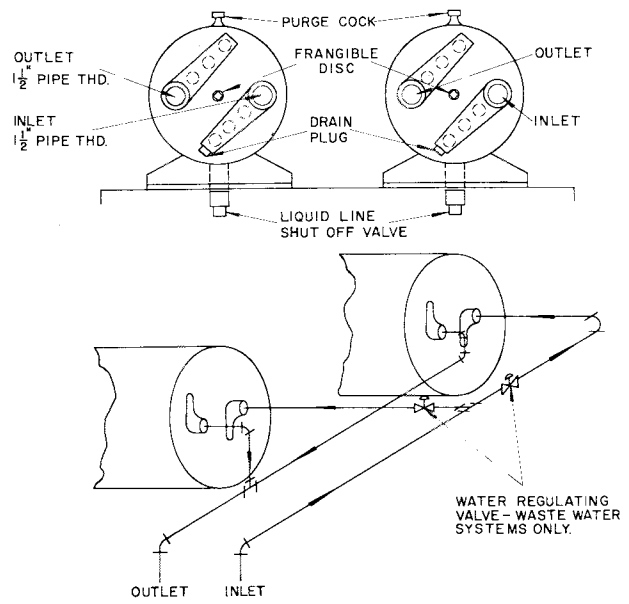

Fig. 11 - 30HH020 Condenser Piping

A30HH-12

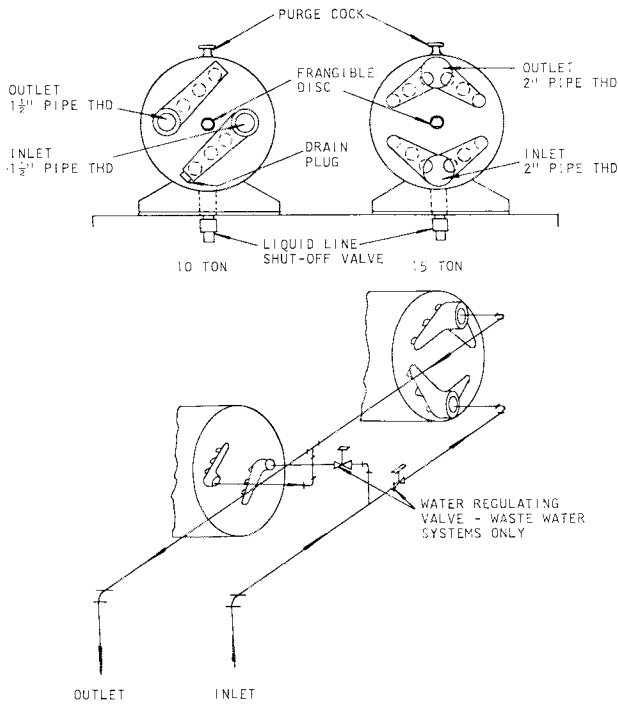

Fig. 12 - 30HH025 Condenser Piping

A30HH-13

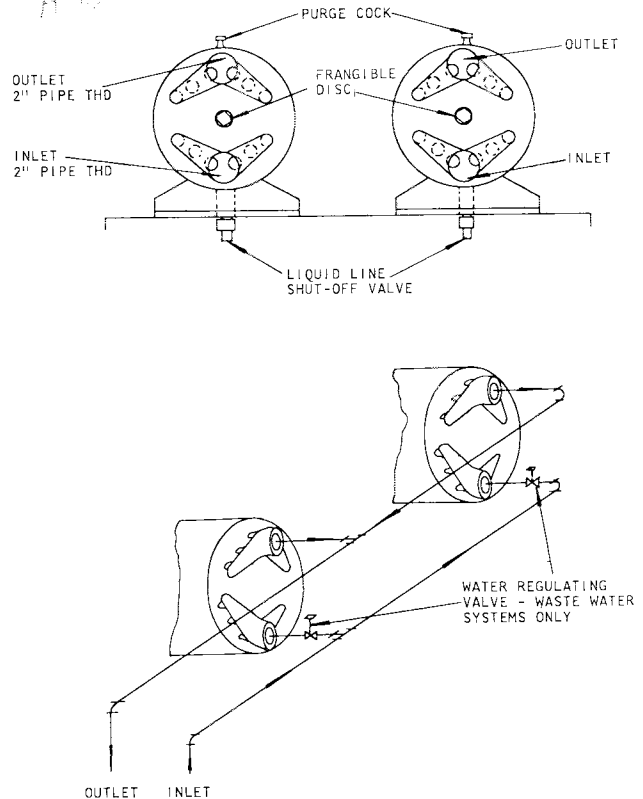

Fig. 13 - 30HH030 Condenser Piping

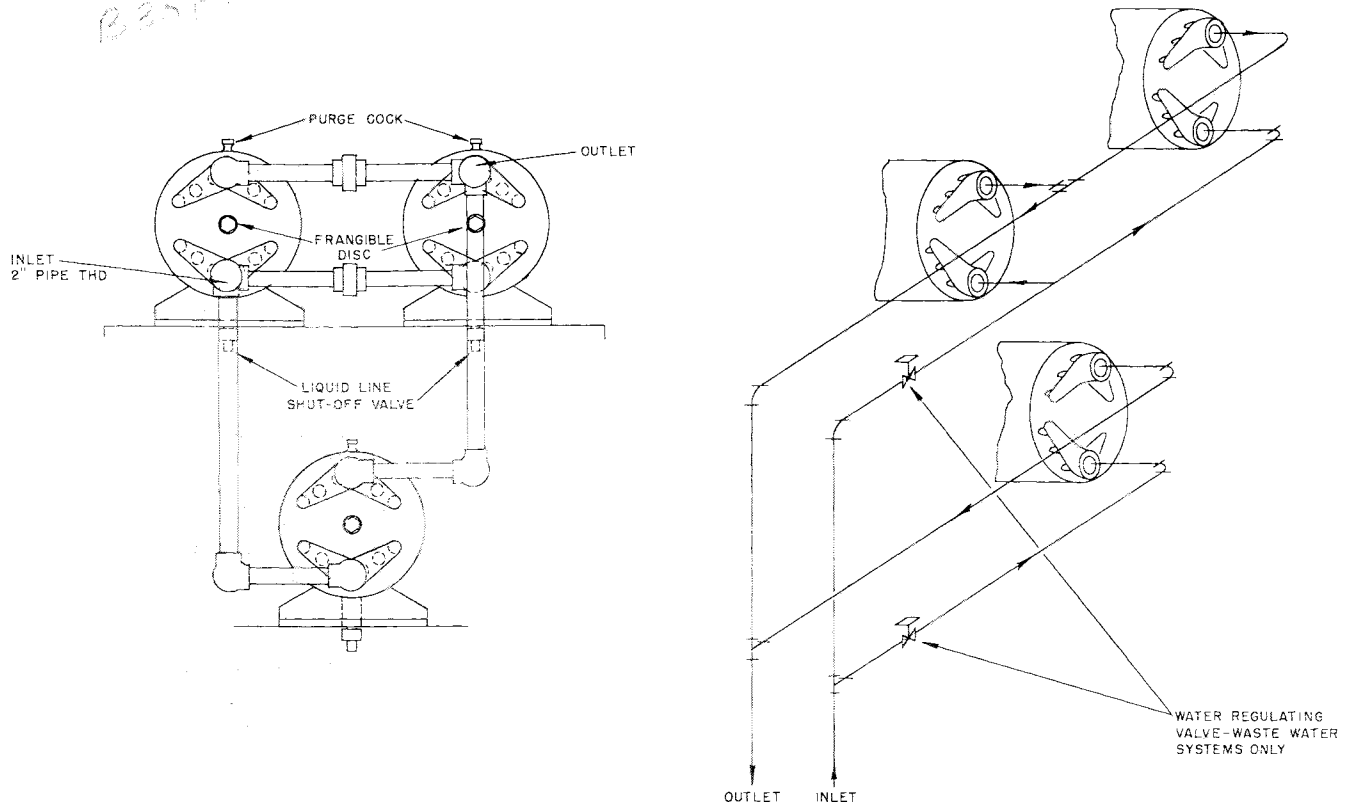

Fig. 14 - 30HH045 Condenser Piping

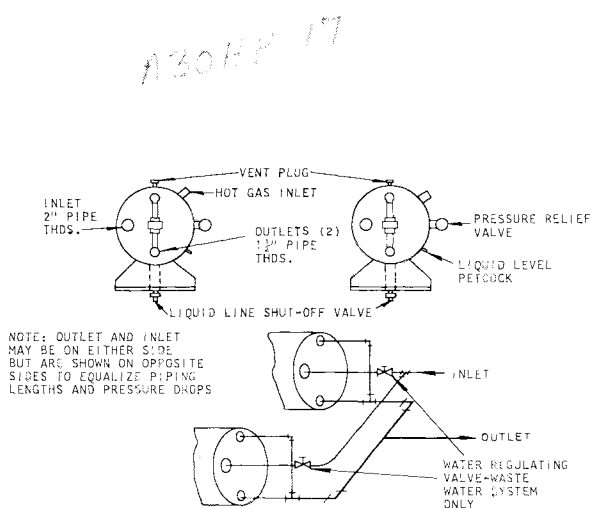

Fig. 15 - 30HH055 Condenser Piping

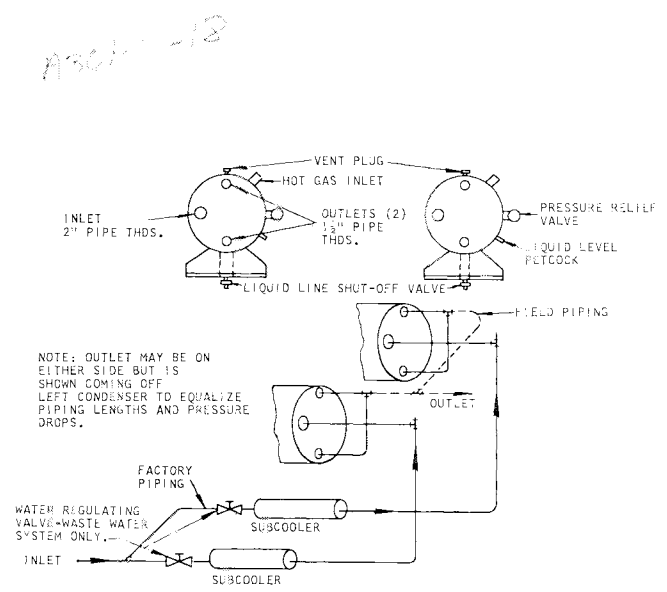

Fig. 16 - 30HH065 Condenser Piping

Drain Connection

Drain connections are generally governed by local codes. Water leaving the condenser is under pressure and should not be connected directly into sewer lines; otherwise water may back up into other fixtures. Local codes normally require connections similar to the one shown in Fig. 17.

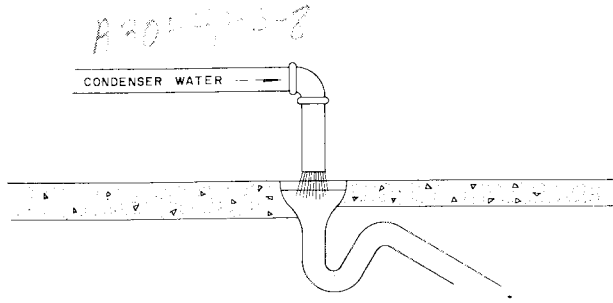

Fig. 17 - Drain Connections

COOLER WATER PIPING

The cooler of each liquid chilling package is provided with stubouts for chilled water piping connections. The water outlet stubout is provided with a 90 degree elbow which contains the chilled water safety thermostat bulb. Holes are provided in both of the side panels for piping to the stubouts.

The chilled water temperature controller is mounted on the front of the unit and has the control bulb and capillary tubing wrapped and taped before shipping. It is required that the control bulb be field inserted in the chilled water line. It usually is inserted in the return or inlet chilled water piping. Figure 18 shows a typical chilled water piping arrangement in the vicinity of the cooler. Details of the required remote chilled water piping are outlined in the Carrier System Design Manual, Part 3, "Piping Design."

Plan the piping so it has a minimum number of changes in elevation. A manual or automatic

vent-valve must be installed at the high points in the line to permit venting of air from the chilled water circuit. Standard practice for installing forced water systems must be followed. System pressures may be maintained by using a pressure tank or a combination relief valve and reducing valve.

It is recommended that thermometers be installed in entering and leaving chilled liquid lines. Provide drain connections at all low points to permit complete drainage of the system. A chiller drain shut-off valve should be connected to the chiller drain line before placing the unit in operation (Fig. 18).

Insulate piping to prevent heat loss and sweating. Cover the insulation with a moisture seal. Do not insulate piping before all leak testing has been completed.

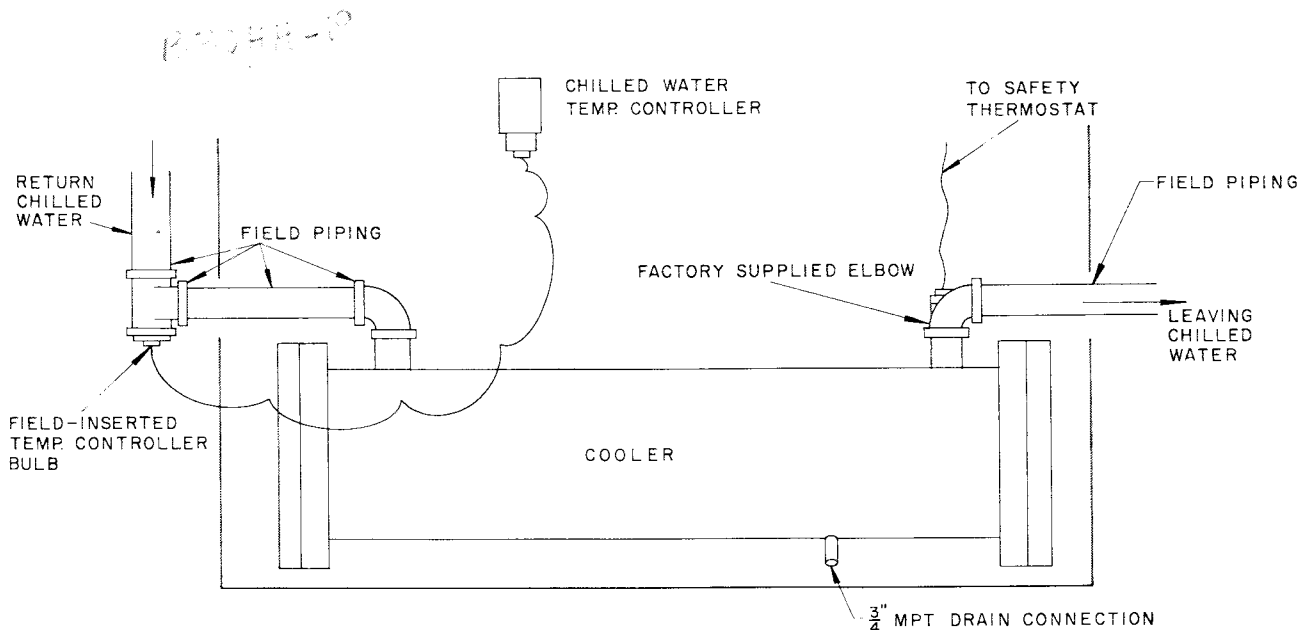

Fig. 18 - Cooler Water Piping, Front View

REFRIGERANT PIPING

For refrigerant piping sizing refer to Part 3 - "Piping Design" - of the System Design Manual.

The 30HH and HJ Packaged Liquid Chillers are leak tested at the factory and provided with a holding charge of Refrigerant 22.

NOTE: 30HH015,020 fully charged with R 22 at factory.

If the holding charge is still in the system upon arrival at the erection site, the likelihood of leaks is slight. If the unit is not under pressure, test for leaks as outlined under Leak Testing.

NOTE: Be sure to open all stop valves when testing for leaks.

30HJ UNIT

This section also applies to the 30HJ unit which is to be connected to a remote condenser in the field. Figure 19 is a typical refrigerant piping diagram showing the 30HJ020 thru 030 unit and a 9H Evaporative Condenser. Similar connections may be used for the 30HJ045 and 065 unit using manifolded compressors. Figure 20-22 illustrate typical refrigerant piping for 30HJ020 thru

065 units and air-cooled condensers. Receivers have been omitted, but it must be recognized that with this arrangement the refrigerant charge is critical. An overcharged or undercharged system can cause a loss of capacity. If a receiver is not included, an accurate refrigerant charge must be maintained to assure efficient operation.

Figure 20-22 are shown to illustrate a typical installation using 9A or 09DC016 air-cooled condensers. These illustrations are to be used as a guide when designing a system and are not intended to be used as an actual piping layout. Consult the "System Design Manual" and condenser literature before designing the actual system.

Each 30HJ unit (except -015) consists of two independent refrigerant circuits. Each circuit must be isolated from the other.

Discharge lines and liquid lines are shown manifolded at the units on 30HJ045 and 065 units to permit a minimum amount of piping. Individual discharge lines may be run from each compressor to the condenser if desirable. Liquid lines must be manifolded as shown to enter the 30HJ065 unit to agree with the unit refrigerant circuit. Individual liquid line connections are necessary on the 30HJ045 unit.

30HH-20

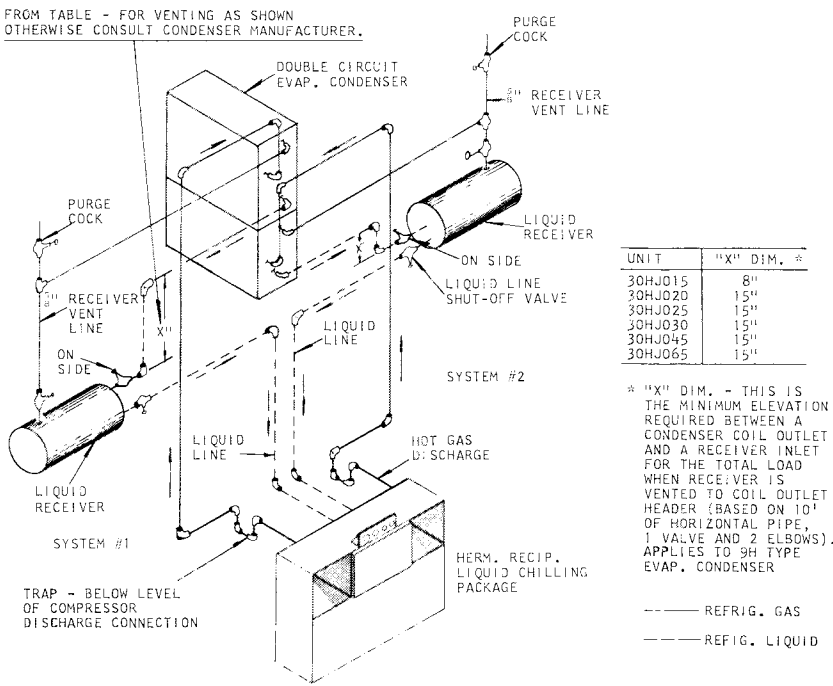

- NOTE: 1. DIAGRAM FOR 30HJ LIQUID CHILLER AND 9H EVAPORATIVE CONDENSER ONLY. WHEN OTHER CONDENSERS ARE USED, SEE MANUFACTURER'S RECOMMENDATIONS.
- 2. MUFFLERS SHOULD BE INSTALLED AS CLOSE TO THE COMPRESSOR AS POSSIBLE.

Fig. 19 - Typical Refrigerant Piping 30HJ020-030 Units with 9H Evaporative Condenser

In order to prevent condensed liquid refrigerant or oil from causing damage to the compressor, install a trap in the vertical discharge line near the compressor. The trap may be installed within or adjacent to the unit base. The height of the trap (or loop) should be 6 inches for every 10 feet of vertical discharge line. If the height of the vertical discharge line is such as to make a single trap impractical, the loop can be replaced by a check valve or several traps.

To prevent the formation of copper oxide when brazing copper tubing, bleed a small amount of dry nitrogen gas thru the piping. The nitrogen will displace the air containing oxygen.

Complete all field piping before removing the seals on the unit refrigerant piping. Upon completion of the field piping, add a small amount of refrigerant and build up the required test pressure with dry nitrogen or other inert gas. If a test pressure is not specified, ASA-B9 Code calls for 300 psig high side and 150 psig low side test pressures for R 22.

- NOTE:**
1. Install mufflers as close to compressor discharge valve as possible.
 2. Make sure a pressure relief device is installed in the hot gas line or condenser used with the 30HJ models.

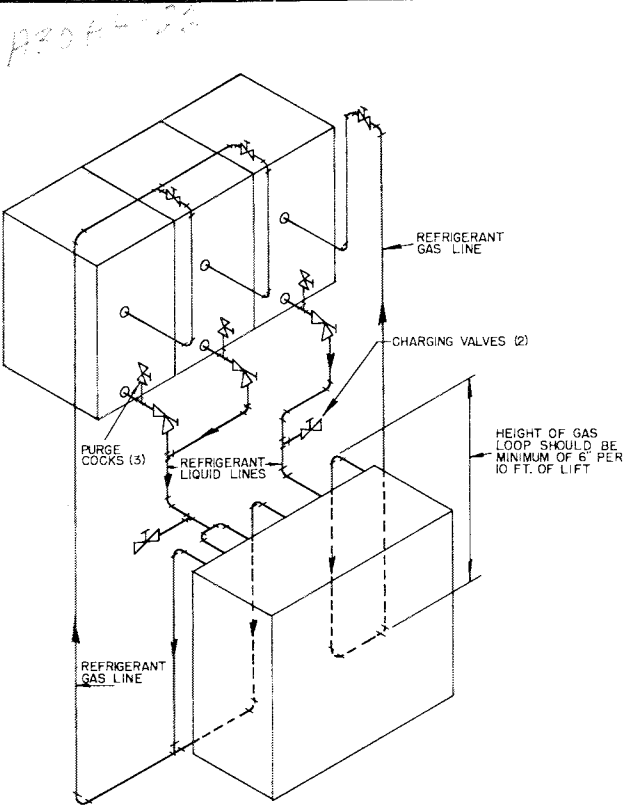

Fig. 21 - Refrigerant Piping to Three Air-Cooled Condensers 30HJ045 (without Receivers)

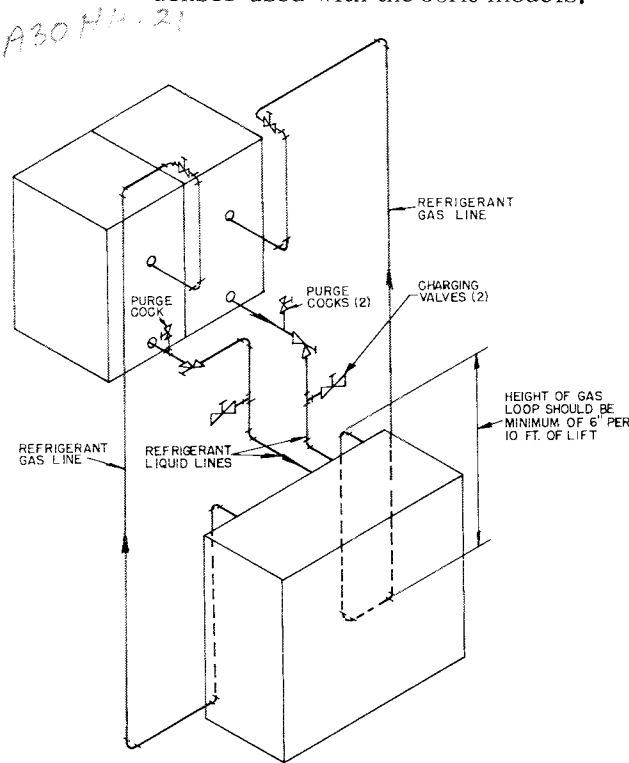

Fig. 20 - Refrigerant Piping to Two Air-Cooled Condensers 30HJ020,025,030 (without Receivers)

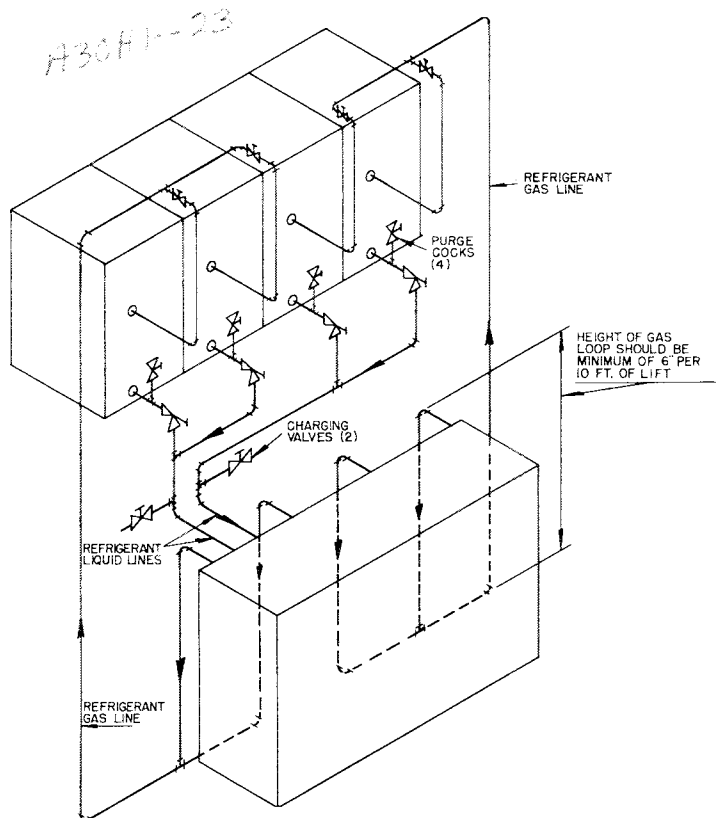

Fig. 22 - Refrigerant Piping to Four Air-Cooled Condensers 30HJ065 (without Receivers)

LEAK TESTING

The Halide Leak Detector

The Halide Leak Detector pictured in Fig. 23 consists of a burner, needle valve, suction tube, and a chimney with a copper reaction plate. Some torches use alcohol and others use propane fuel.

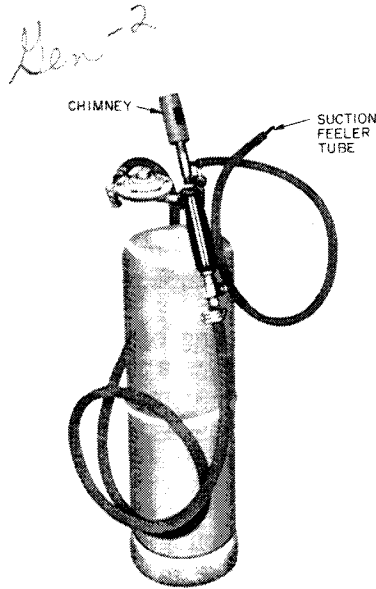

Fig. 23 - Halide Leak Detector

To use the leak detector:

1. Adjust the flame so the top of the flame cone is level with or slightly above the chimney.
2. Place the end of the suction tube at the point to be tested. The tube pulls in a sample of air to the burner where the refrigerant is decomposed by reaction with the copper plate.
3. Observe the color of the flame. Small leaks give a greenish tint and large ones a vivid blue. Leaks can also be detected with a soap solution or an electronic gun.

DEHYDRATE THE SYSTEM

If there has been a leak in the 30HH unit or after field piping the 30HJ unit, the system must be evacuated.

Moisture in the system causes oil-sludge and corrosion. It is likely to freeze up the expansion valve of a low temperature system. The best means of dehydration is evacuation with a pump specially built for this purpose.

Preparation

Before dehydrating a system make the following preparations:

1. Obtain a pump that will produce a vacuum of .2" Hg absolute. Do not use the compressor as a vacuum pump. It is not designed for such use and may be seriously damaged.
2. Pressure test system to be sure it is free of leaks.
3. Obtain a vacuum indicator similar to that shown in Fig. 24 (available thru local Carrier Distributor).
4. Keep the ambient temperature above 60 F to speed the evaporation of moisture.

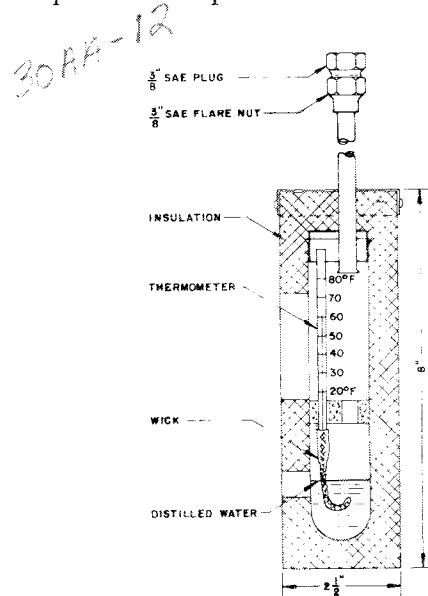

Fig. 24 - Vacuum Indicator

Description and Use of the Vacuum Indicator

The vacuum indicator consists of a wet bulb thermometer in an insulated glass tube containing distilled water. Part of the tube is exposed so the thermometer can be read and the water level checked. When the vacuum indicator is connected to the vacuum pump suction line, the thermometer reads the temperature of the water in the tube. The temperature is related to the absolute pressure in the tube. Table 7 gives the absolute pressures corresponding to various temperatures.

Handle the vacuum indicator with care. It must be vacuum tight to give a true reading. The top



Table 7 - Vapor Pressures of Water

Temperature, degrees F Observed on Vacuum Indicator	Absolute Pressure Inches of Mercury
70	0.739
60	0.522
55	0.436
50	0.363
45	0.300
40	0.248
35	0.204
32	0.180

NOTE: To determine the vacuum in inches of mercury subtract the absolute pressure from the barometer reading.

seal of the indicator is not designed to support a long run of connecting tubes. Fasten the tubes to supports to prevent damage.

Use only distilled water in the indicator. Be sure the wick is clean. Oil or dirt on the wick causes erroneous readings. To prevent loss of oil from the vacuum pump and contamination of the indicator:

1. Install a shut-off valve in the suction line at the vacuum pump.
2. Install a shut-off valve in the suction line at the vacuum indicator.
3. When shutting off the pump, close the indicator valve, the pump valve and turn off the pump in that sequence.

Procedure for Dehydrating the System

1. Connect the pump and vacuum indicator to the system. Put a "jumper" line between the high and low side so that the pump will draw a vacuum on all portions of the system. Open the compressor shut-off valves. Start the pump.
2. Open the indicator connection shut-off valve occasionally and take a reading. Keep the valve open at least three minutes for each reading. (Keep the valve closed at all other times to decrease the amount of water the pump must handle and hasten dehydration.) When the pressure in the system drops to a

value corresponding to the vapor pressure of the water in the indicator, the temperature will start to drop. In the example shown in Fig. 25, the ambient temperature and the temperature of the water in the indicator is 60 F. Starting at 60 F and 0 time the temperature of the water in the indicator remains at 60 F until the pressure in the system is pulled down to the pressure corresponding to the saturation temperature of the water (60 F).

At this point the moisture in the system will start to boil. The temperature drops slowly until the free moisture is removed (35 F). Dehydration is nearly completed at this point provided the ambient temperature remains at 60 F or higher. If the ambient temperature were lower than 60 F ice might form before moisture removal is complete.

3. Continue the dehydrating operation until the vacuum indicator shows a reading of 35 F which corresponds to a pressure of 0.204" Hg absolute. This may take several hours. It may be advantageous to run the pump all night.
4. With the pump still running, open the system at a point furthest from the pump and admit air thru the drier. Close system and repeat steps 2 and 3. Vapor left in the system is thus greatly diluted and almost completely removed by double dehydration.
5. After evacuation, turn off the pump suction valve and break the vacuum by admitting refrigerant.

START-UP PROCEDURES

Initial Check

Do not attempt to start the 30HH and HJ Liquid Chiller even momentarily until the following steps have been completed.

1. Check all auxiliary components of the installation such as chilled liquid circulating pump, cooling tower if used, air handling equipment, or other equipment to which the chiller supplies liquid. Consult the manufacturer's instructions.
2. Check safety thermostat. See "Safety Thermostat Adjustment" under "CHECKING THE CONTROLS."
3. Backseat (open) the compressor suction and discharge shut-off valves. Close the valves

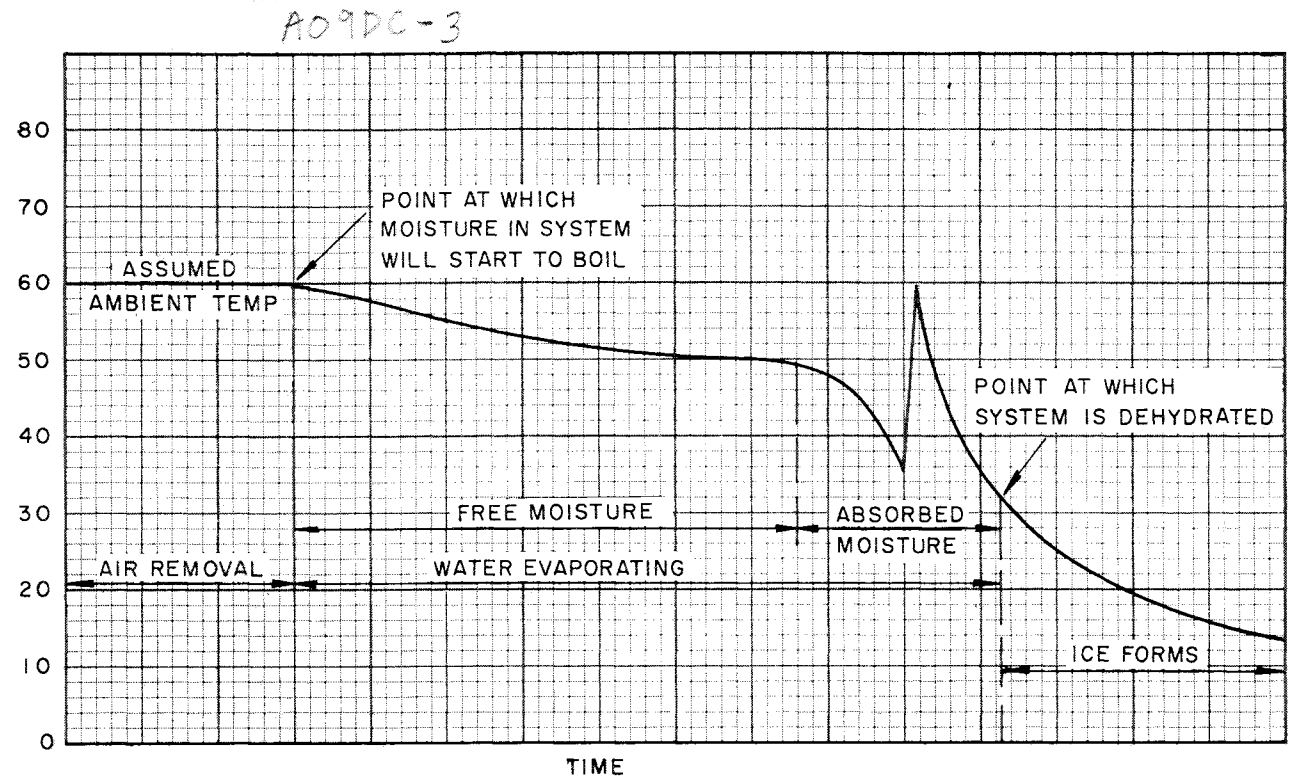

Fig. 25 - Dehydration Pull-Down Curve

- one turn to allow pressure to reach the gages.
4. Open the liquid line shut-off valves at the condensers (30HH if using the vapor charging method - see "Charge With Refrigerant") or the inlet, outlet, and vent valves on the receivers (30HJ).
 5. Open the valves to the capillaries of the water regulating valves (when used).
 6. Fill the chilled liquid circuit completely with clean water or other non-corrosive fluids to be cooled. Bleed all air out of the high points of the system.
 7. If the condenser is cooled by waste water, open the water supply valve. If it is cooled by a cooling tower, fill the tower with water.
 8. Start the air handling equipment or other equipment to which the 30HH or HJ is connected.
 9. Set the temperature controller (page 24).
 10. Check tightness of all electrical connections.
 11. Remove cardboard spacer from recycle re-

lay and remove protective paper between contacts of the balancing relay in the step controller.

Start Up

Upon completing the initial check, charge the unit with refrigerant. (See "Charge with Refrigerant.")

IMPORTANT: 30HH015,020 units are fully charged at factory.

The unit should only be started under the supervision of a refrigeration mechanic who is familiar with the accepted operating practices for refrigeration systems.

1. Open all compressor or system valves that may have been closed during or after charging.
2. Start the unit by pushing the "START" and "STOP" button.
3. Check all controls for proper operation. (See "Check Controls.")
4. Adjust water regulating valve to the most economical pressure for the locality. Normally 200 to 230 pounds for F 22.

B30HH-24

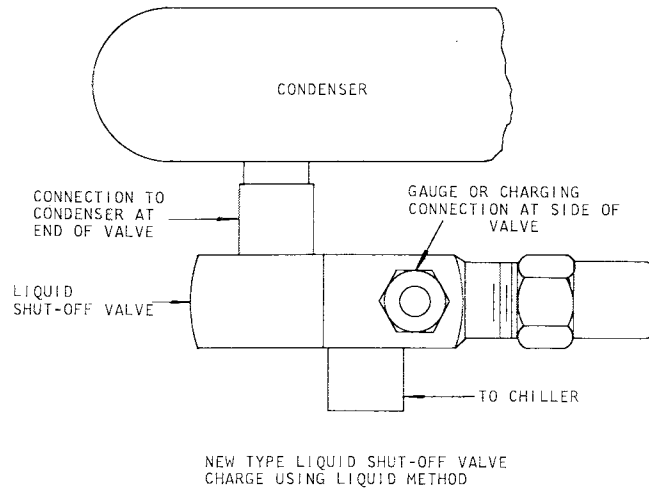
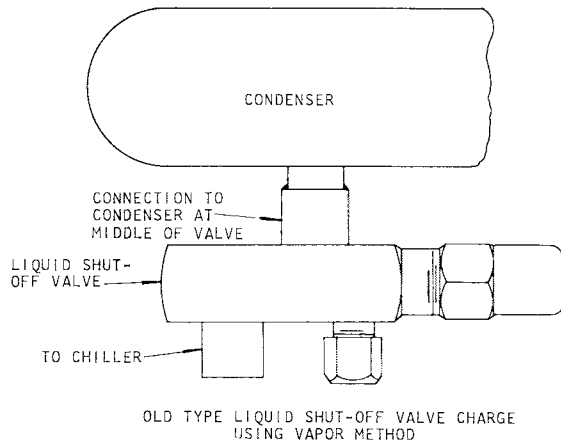

Fig. 26 - 30HH Condenser Liquid Line Shut-Off Valves

5. Check chiller leaving temperature to see that it remains well above freezing.
6. Check compressor oil level ("Oil Charge").

CHARGE WITH REFRIGERANT

Each system in the 30HH and HJ units must be charged individually.

IMPORTANT: 30HH015,020 units are fully charged at factory.

Charge early models of the 30HH015 to 030 units using the vapor charging method.

Charge later models of the 30HH units using liquid charging method. A redesign of the condenser liquid shut-off valve makes it possible to charge liquid refrigerant thru the gage port directly into the chiller, when the valve is in the front seated position. Check Fig. 26 showing both valves to determine the method of charging to be used.

CAUTION: When charging the units, circulate water thru the condenser (30HH) and chiller (30HH and HJ) at all times to prevent freezing. Freezing of equipment with resulting damage is considered abuse and not covered by the Carrier Warranty.

Vapor Charging Method

Vapor charge the units thru compressor suction shut-off valves as follows:

1. Backseat the suction shut-off valve.

2. Connect a refrigerant cylinder loosely to the gage connection of the suction shut-off valve. The charging line should contain a drier.
3. Purge the charging line and tighten the connections.
4. Turn the stem of the suction shut-off valve clockwise a couple of turns.
5. Stand the cylinder upright so that only gas is charged into the system. Crack valve on the charging cylinder and break vacuum (30HJ units) with refrigerant vapor. Open the valve of the charging cylinder and start the compressor. (See "Start-Up Procedures.") Allow the compressor to cycle on the low-pressure cut-out until the refrigerant charge builds up sufficiently to permit continuous compressor operation.

As the cylinder is discharged, its pressure will eventually drop to the same level as suction pressure. The remaining refrigerant can be drawn from the cylinder by front seating the suction shut-off valve and pulling a vacuum on the cylinder.

6. Check the refrigerant charge frequently at the moisture liquid-indicator. A steady flow of liquid refrigerant will indicate a sufficient charge.
7. When the unit is sufficiently charged, close the cylinder valve, backseat the suction shut-off valve, and remove the charging apparatus.

Replace the plug in the suction shut-off valve.

Liquid Charging Method

Liquid charge the units thru the condenser liquid line shut-off valves.

1. Backseat condenser liquid line shut-off valve.
2. Connect a refrigerant cylinder loosely to the gage connection of the condenser liquid line shut-off valve. Purge the charging line and tighten the connections.
3. Weigh the refrigerant cylinder (if possible).
4. Front seat the condenser liquid shut-off valve.
5. If the system has been dehydrated and is under vacuum, break vacuum with refrigerant (Gas charge). Build system pressure to 58 psi for R 22 (32 F). Invert refrigerant cylinder so that liquid refrigerant will be charged.
6. Allow the compressor to cycle on the low pressure cut-out until sufficient pounds of refrigerant have been added (Table 6).
7. When the unit is sufficiently charged, close the cylinder valve, backseat the liquid line shut-off valve, and remove the charging apparatus. Replace the cap in the liquid line shut-off valve.

NOTE: Where it is impossible to weigh the refrigerant cylinder, the initial refrigerant charge must be an approximation. After it has been added, backseat the liquid line shut-off valve and allow the unit to operate. A clear flow of liquid in the liquid-moisture indicator, indicates a satisfactory charge. If the charge is not sufficient, add refrigerant until a clear flow of liquid show in the glass.

CAUTION: Be careful not to overcharge the system. Overcharging results in:

- (a) Higher discharge pressure with higher cooling water consumption.
- (b) Possible compressor damage.
- (c) Higher power consumption.

OIL CHARGE

The 30HH,HJ units are charged with oil at the factory (Table 2). Because of added piping with

evaporative condenser models, it may be necessary to add oil at the job site. Observe the oil level closely at startup and add oil, if required, to bring the level in the crankcase to the middle of the bull's-eye during steady operation.

To Add Oil

1. Close suction shut-off valve and pump down crankcase to 2 psig. (Low pressure cut-out must be shorted.) Wait a few minutes and repeat as needed until pressure remains at 2 psig.
2. Remove oil fill plug to the right of the bull's-eye and add oil thru plug hole.
3. Replace plug.
4. Run compressor for about 20 minutes and check the oil level.

CAUTION: To insure trouble free operation, use only Carrier approved compressor oil, Specification No. PP-33-2. Do not re-use oil that has been drained out, or oil that has been left open to the atmosphere.

To Remove Oil

1. Pump down compressor to 2 psig gage.
2. Loosen the 1/4" pipe plug in compressor base and allow the oil to seep out past the threads of the plug.

CAUTION: The crankcase will be under slight pressure. Be careful not to remove the plug; the entire oil charge may be lost.

CHECK THE CONTROLS

Expansion Valve

The thermal expansion valves control the flow of liquid refrigerant by maintaining constant superheat of the vapor leaving the cooler. They are pre-set at the factory to maintain a superheat of 8 F. Do not attempt to adjust them unless you are certain it is absolutely necessary.

Safety Thermostat Adjustment

The safety thermostat is of non-cycling, manual reset type. It has an adjusting dial with a stop set at 36 F for normal chilled water applications, but can be readjusted for a lower stop if

glycols or brines are to be cooled. The adjustment tolerance is commonly ± 1 F.

DAMAGE DUE TO THE FREEZING OF A CHILLER IS NOT COVERED BY THE WARRANTY.

The safety thermostat bulb is located in the leaving chilled water piping stubout.

IMPORTANT: This thermostat should be checked at the time of installation and at least once every season. If the bulb is damaged in handling, its calibration may be off.

To check the safety thermostat:

1. Place the thermal bulb in a vacuum bottle filled with water and add crushed ice.

NOTE: This is an insert type bulb. On earlier units, removal opens water system except on 30HH,HJ045 thru 065 units which use a sealed well. Later units all use a sealed well.

2. Stir the contents with a thermometer and note the temperature at which safety thermostat cuts out.
3. Reset the safety thermostat if necessary. To set the control, use screwdriver in slot and rotate dial until the desired temperature at which compressor is to stop is directly under indicator "B".

To recalibrate the safety thermostat:

1. Measure the temperature as close to the bulb as possible, immediately after the compressor stops.
2. Break the painted seal between the dial and the adjusting plate with a knife.
3. Carefully loosen the two dial screws. Be careful not to turn the brass cylinder below the dial during this or any of the following operations.
4. Turn the dial ONLY so that the fixed indicator points to the temperature measured at step 1.
5. Carefully tighten the dial screws.

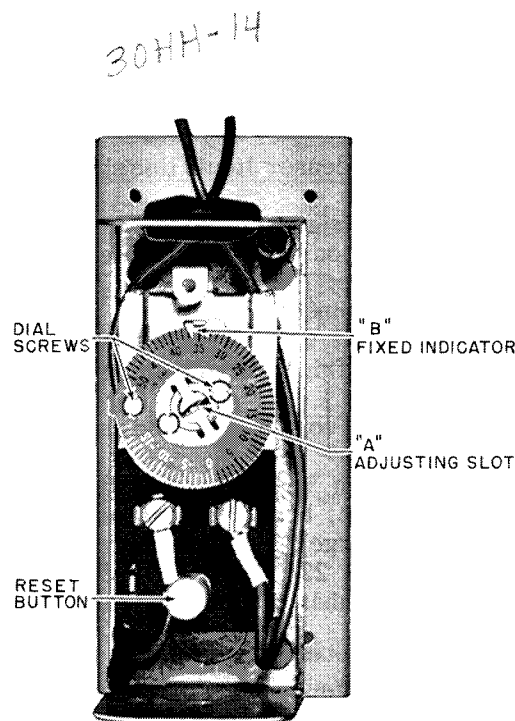

Fig. 27 - Safety Thermostat

High and Low Pressure Controls

Pressure control settings are shown in Table 8.

The 30HJ high pressure control settings are suitable for use with either air-cooled or evaporative condensers. The control setting (Table 8) is a fixed setting and is nonadjustable.

Check the high pressure switch setting by slowly closing the discharge shut-off valve. The compressor should shut down when the discharge pressure reaches 260 or 355 psi (as required) and start up when the pressure drops to 210, or 255 psi (as required).

The 30HH high pressure switches are adjustable and equipped with a stop to prevent field setting above 280 lbs.

To check the low pressure switch, close the suction shut-off valve and allow the compressor to pump down. The compressor should cut out when the suction pressure falls to 46 psig, and automatically start up again when the suction pressure builds up to 83 psig.

Both sides should be checked at startup and at least once a year thereafter.

Table 8 - Pressure Control Settings

Model	High Pressure Cutout		Low Pressure Cutout	
	Cutout (psig)	Cut-in (psig)	Cutout (psig)	Cut-in (psig)
30HH	260	210	46	83
30HJ	355	255	46	83

Liquid Line Solenoid Valves (30HJ models only) - All 30HJ condenserless models are provided with a liquid line solenoid valve in each refrigerant circuit. These valves and the low pressure cut-out switches provide pumpdown control of idle refrigerant circuits when the unit is in operation.

Crankcase Heaters

All compressors are furnished with crankcase heaters to prevent accumulation of liquid in the compressors. They are inserted into blind holes in the compressor bottom cover. Electrically, they are wired into the control circuit by connecting them to the normally closed auxiliary contacts on the compressor starters. The crankcase heaters are energized at all times when the unit is not in operation.

Electrical Characteristics: 75 watt, 230 volt, single phase, 50/60 cycle for each crankcase heater on 230 volt units; 75 watt, 115 volt single phase, 50/60 cycle for 460 volt and 575 volt units.

STARTERS AND OVERLOADS

The starters have been selected and the overloads have been sized at the factory to give proper protection to the compressor motor. Do not increase their size or bypass their connections. If trouble is encountered, the cause should be found and corrected before the overloads are reset.

Compressor Thermal Protection

An internal thermostat is located in the motor windings of each compressor. Should the temperature of the compressor rise too high, the thermostat will trip and stop the compressor. It will not restart until the temperature drops. On the part winding compressor, the thermostat is located externally on the compressor housing.

CIRCUIT BREAKERS

Circuit breakers provide separate branch circuit protection, one for each compressor. They are jumpered so that only one power lead to the unit is required.

When branch circuit overload causes the breakers to trip, they must be manually reset, by throwing the switch off and on again. The cause of the overload should be determined and remedied before restarting.

Control Circuit

To stop unit, push "STOP-START" button in center of the gage panel.

Table 9 - Circuit Breaker Trip Amperes

Compressor and Unit	Circuit Breaker Size (Amps)			
	208-3-60 230-3-60	230-3-50	460-3-60 400-3-50	575-3-60
6D73 (HH)	90	90	40	40
6D75 (HJ)	90	90	50	40
6D68 (HH)	50	50	25	20
6D68 (HJ)	70	50	30	30

Two eight ampere fuses protect the control circuit against overload. The control light will be on whenever the fuse control circuit is energized. Disengage the fuse caps to remove blown fuses.

30HH-3

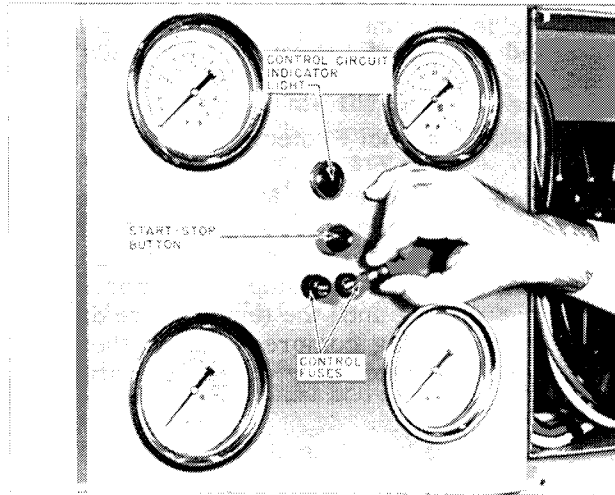

Fig. 28 - Gauge Panel (30HH,HJ045)

WATER REGULATING VALVE

The water regulating valve should be set to maintain the most economical head pressure as determined by the design engineer, based on the relative cost of water and electricity in a given area. It should not be adjusted to compensate for high head pressures caused by fouled condenser tubes, excess refrigerant or the presence of noncondensables. Due to changes in water temperatures, it may be necessary to adjust the valve seasonally. After adjusting for the economical head pressure, the machine should be shut down. The water regulating valve should shut off the flow of water in a few minutes. If it does not, it will be necessary to raise the head pressure setting. The water regulating valve is used for city water and in some cases with multiple units on a single cooling tower.

TEMPERATURE CONTROLLER ADJUSTMENT

The chilled water temperature controller must be adjusted in the field before initial startup. Two adjustments are required - Set Point (main scale, 15 - 90 F) and Throttling Range (modulating, min - F).

The set point is determined as follows:

$$\text{Set Point} = \text{Design Leaving Chilled Water Temperature} - "X"$$

The "X" values (Table 10) were established by experimentation and are such that the compressor is prevented from cycling more than once in a five minute period.

The throttling range is determined as follows:

$$\text{Throttling Range (modulating)} = \text{Design Rise} + "X"$$

The throttling range setting is arrived at by entering the graph below at the "set point" and moving across an amount equal to the throttling range. The setting is read from the top scale and will fall somewhere between min. - F. To illustrate, with a 30HH065 Chiller, a 4-compressor unit, at a 10 F design rise, 45 F leaving chilled water temperature, the set point would be $45 - 1 = 44$ F. The throttling range would be $10 + 1 = 11$ F.

Entering the graph at 44 F and moving across 11 F indicates a throttling range setting of just under "A".

Table 10 - "X" Values, F

No. of Comp.	Design Rise F		
	8	10	12
1	2.0	2.5	3.0
2	2.0	2.5	3.0
3	1.25	1.5	1.75
4	.75	1.0	1.25

30HH-15

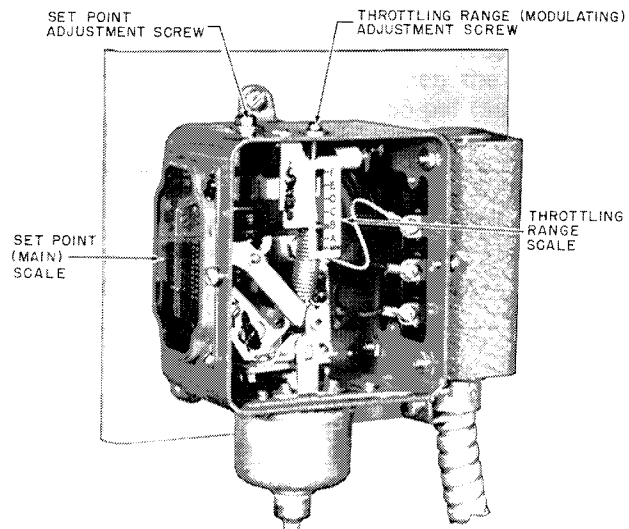

Fig. 29 - Chilled Water Temperature Controller

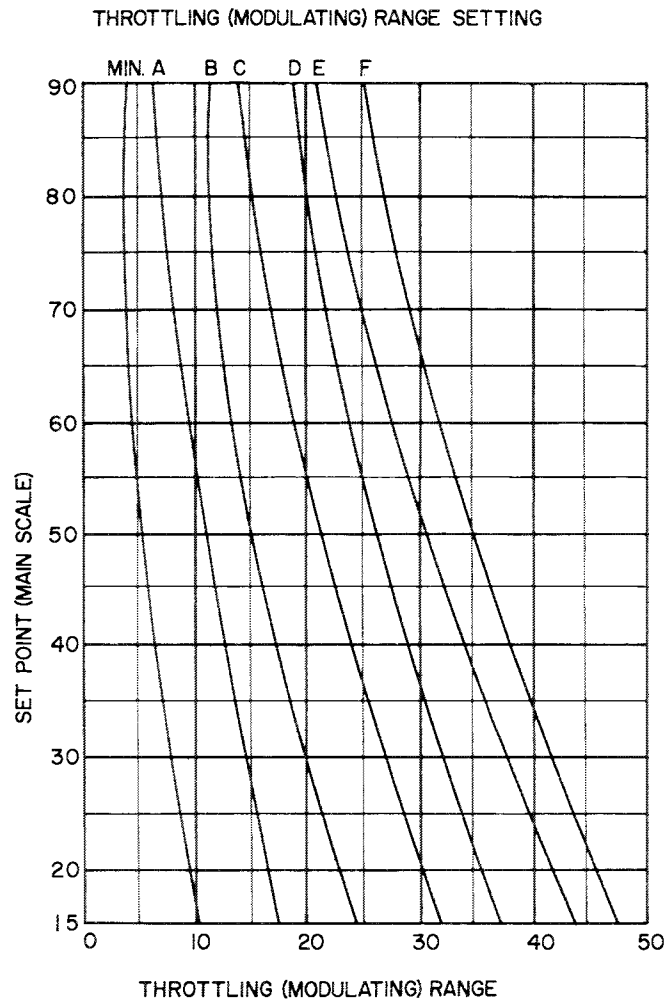

Fig. 30 - Temperature Controller Graph

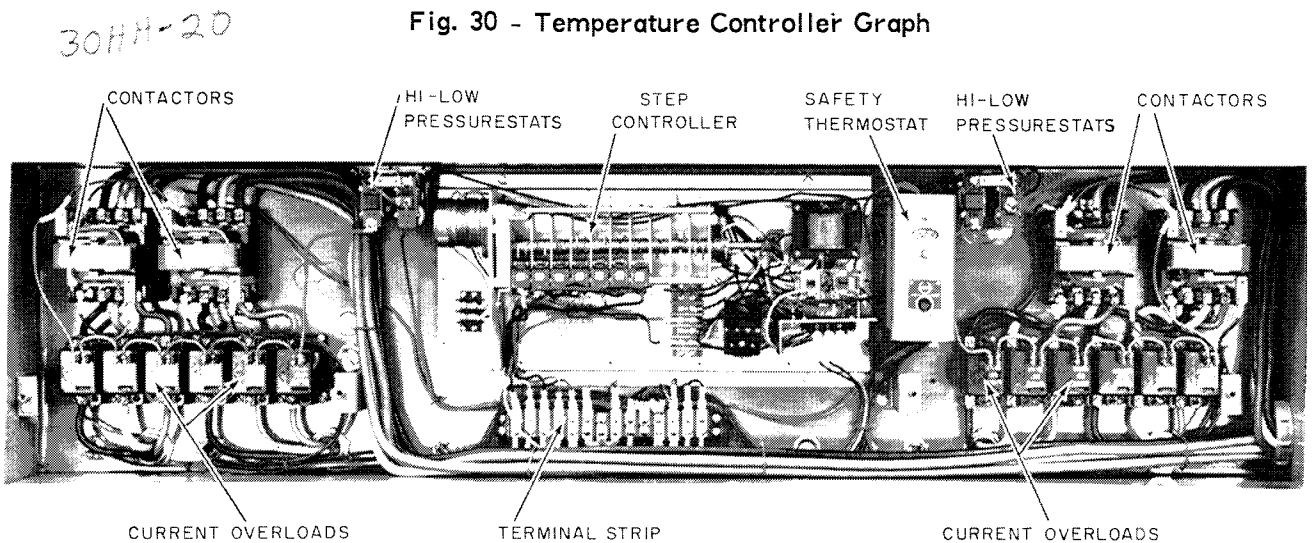

Fig. 31 - Control Box - 30HH,HJ065

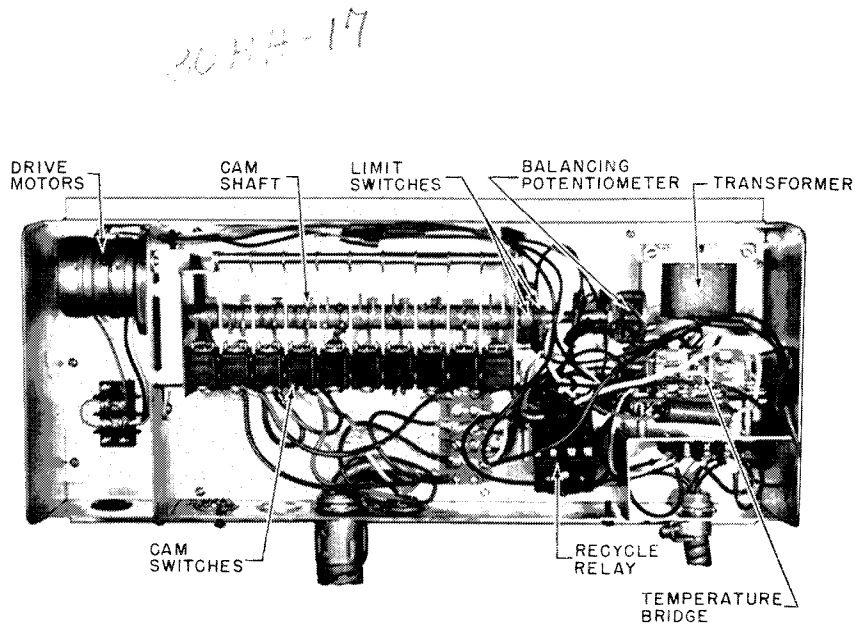

Fig. 32 - Step Controller

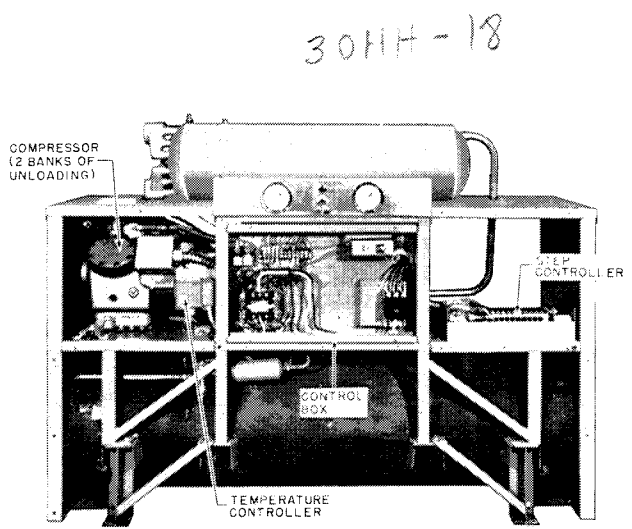

Fig. 33 - 30HH015 Chiller with Front Panel Removed

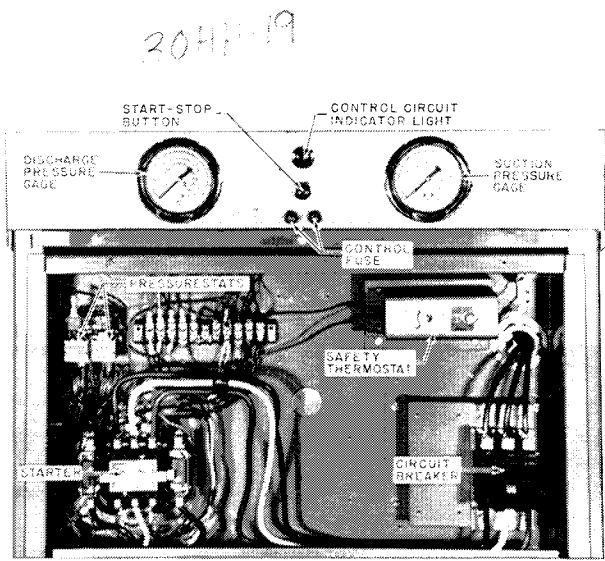

Fig. 34 - 30HH015 Control Panel

Rem. Range 30HH-27-41

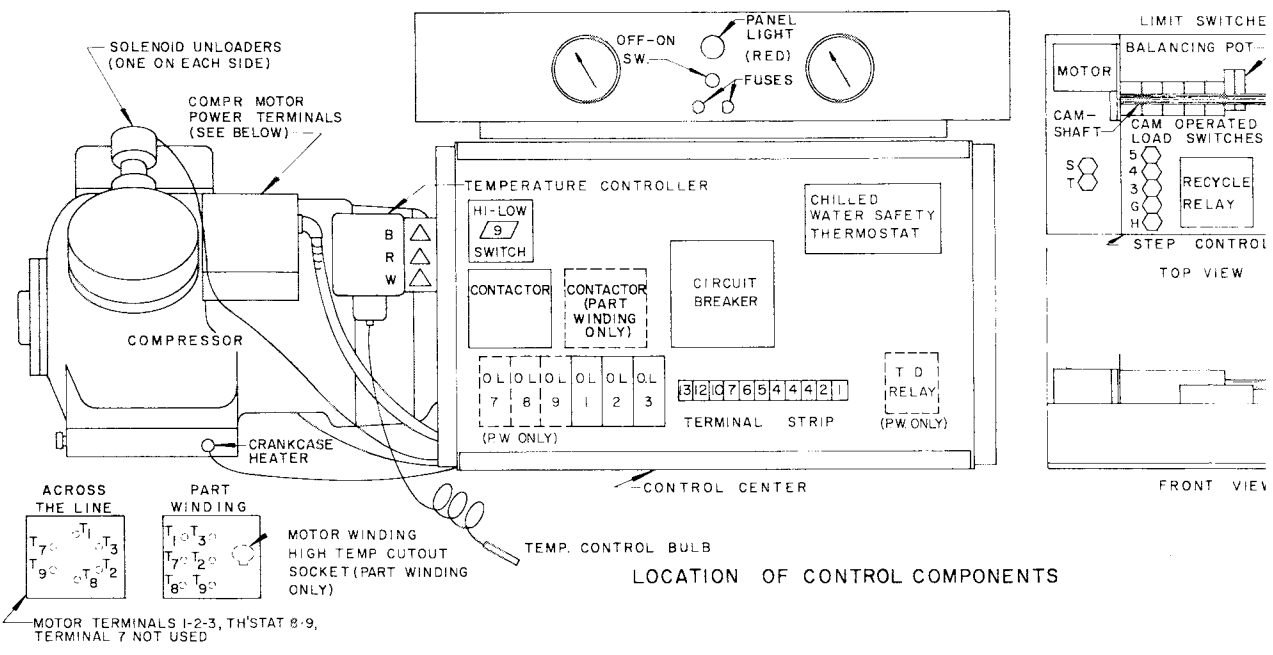
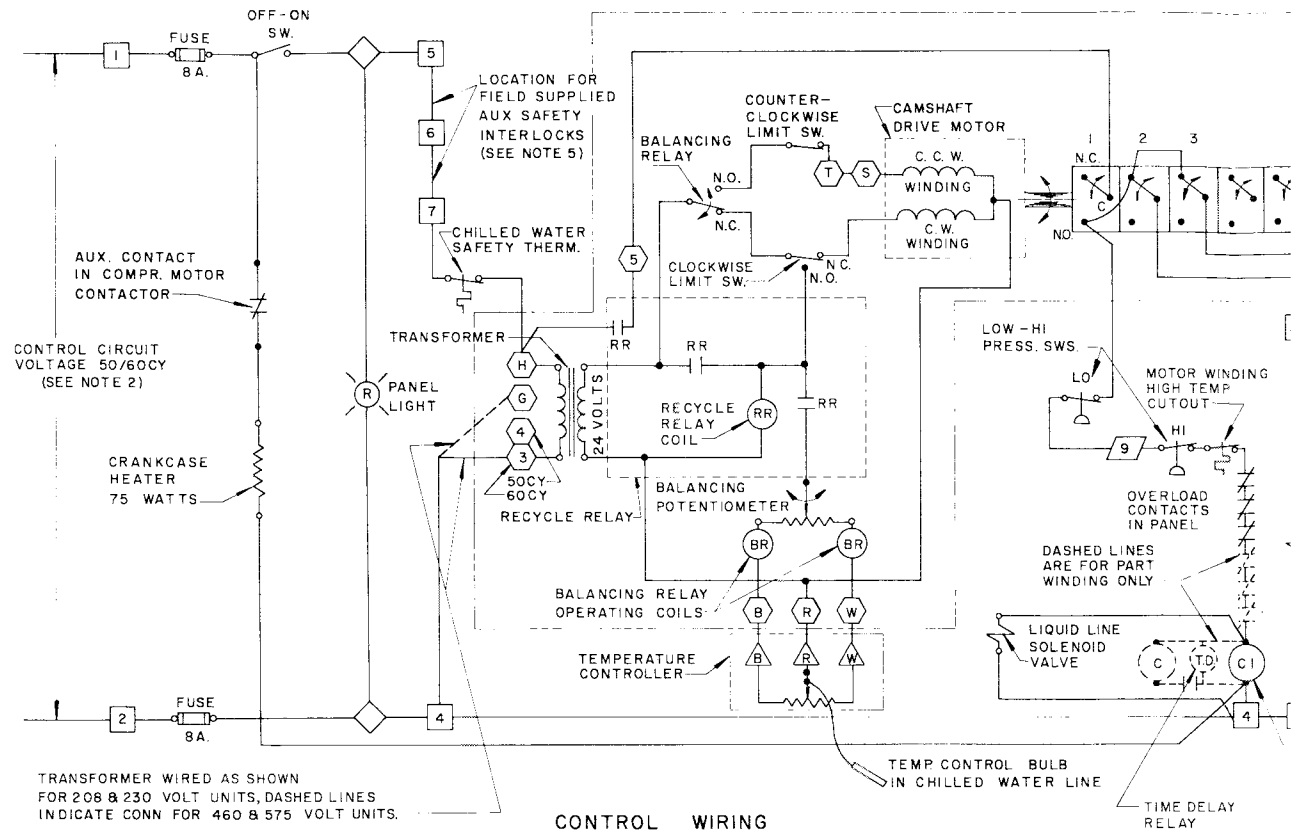
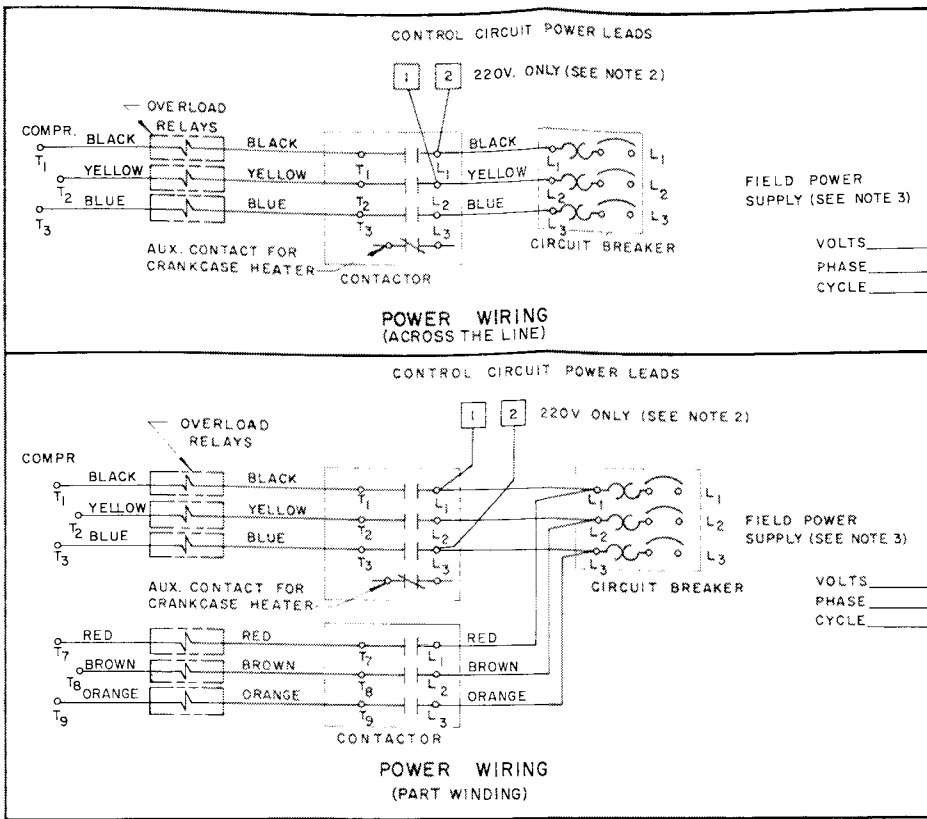

Fig. 35 - 30HH, HJ015 Wiring Diagram (



LEGEND

- TERMINALS ON MAIN TERMINAL STRIP
- ◇ TERMINALS ON PANEL LIGHT
- ⬡ TERMINALS ON STEP CONTROLLER
- ▭ TERMINALS ON PRESS. SWITCH
- △ TERMINALS ON TEMPERATURE CONTROLLER

NOTES

1. ALL WIRING SHOWN IS FACTORY WIRING EXCEPT AS OUTLINED IN NOTE 2.
2. 208 VOLT & 230 UNITS HAVE 208/230 VOLT CONTROL CIRCUITS. ON THESE UNITS ONLY, LEADS ARE SUPPLIED FROM NUMBER 1 CONTACTOR TO TERMINALS 1 & 2. FOR THE PURPOSE OF ENERGIZING THE CONTROL CIRCUIT. 460 & 575 VOLT UNITS HAVE 115 VOLT CONTROL CIRCUITS, AND A SEPARATE 115 VOLT SOURCE MUST BE FIELD SUPPLIED THROUGH A FUSED DISCONNECT SWITCH TO TERMINALS 1 & 2.
3. FACTORY WIRING IS IN ACCORDANCE WITH THE NATIONAL ELECTRICAL CODE. ANY FIELD MODIFICATIONS OR ADDITIONS MUST BE IN COMPLIANCE WITH ALL APPLICABLE CODES.
4. CONTROL CIRCUIT FUSES MUST ALWAYS REMAIN IN THE CONTROL CIRCUIT. THE FUSES ARE 1/4" x 1 1/4" CERAMIC TUBE RATED AT 8 AMPS FOR 220 VOLT CIRCUITS AND 15AMPS FOR 115 VOLT CIRCUITS.
5. MINIMUM SWITCH RATING FOR TERMINALS 5, 6 AND 7 AT 220 VOLTS IS 500 VOLT-AMPERES EACH. REMOVE JUMPERS AS REQUIRED FOR AUXILIARY INTERLOCKS.
6. MAXIMUM EXTERNAL CONTINUOUS LOADS TO BE CONNECTED BETWEEN TERMINALS 4 AND 9, AND TERMINALS 4 AND 5 ARE 250 VOLT-AMPERES EACH.
7. LOAD SWITCHES ARE SHOWN WITH UNIT FULLY UNLOADED. CAMSHAFT MOTOR RUNS CC W. (FROM POTENTIOMETER END) TO OPERATE LOAD SWITCHES 1 THRU 3 IN SEQUENCE AS CHILLED WATER TEMPERATURE INCREASES.
8. 150VA TRANSFORMER REQUIRED FOR DEVICES SHOWN ON CONTROL WIRING DIAGRAM. IF ADDITIONAL CONTROLS ARE USED, THE TRANSFORMER SIZE MUST BE INCREASED ACCORDINGLY.

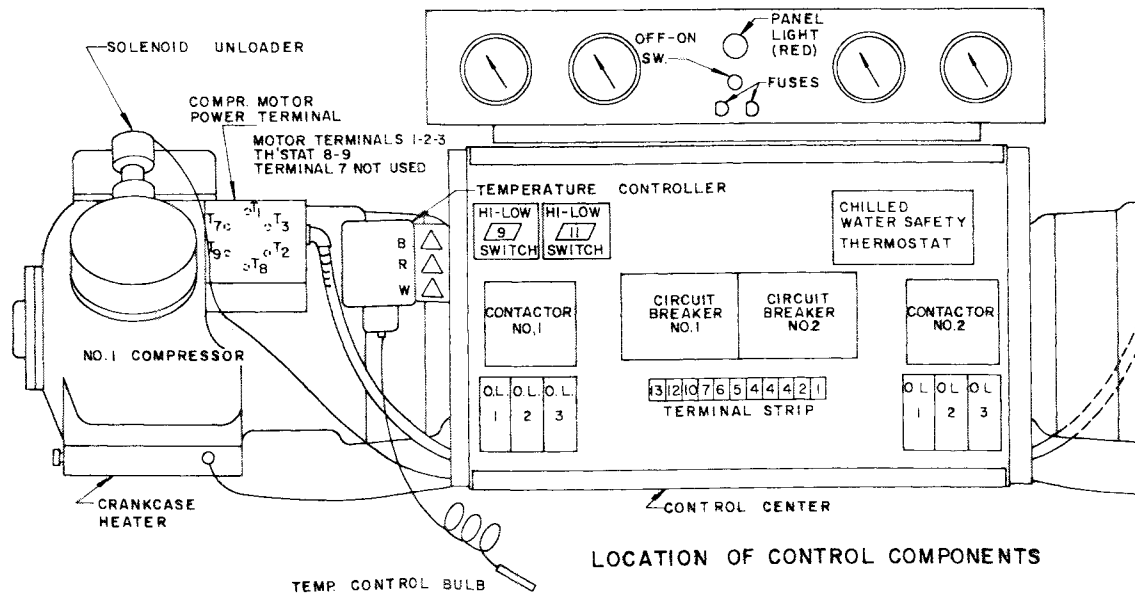
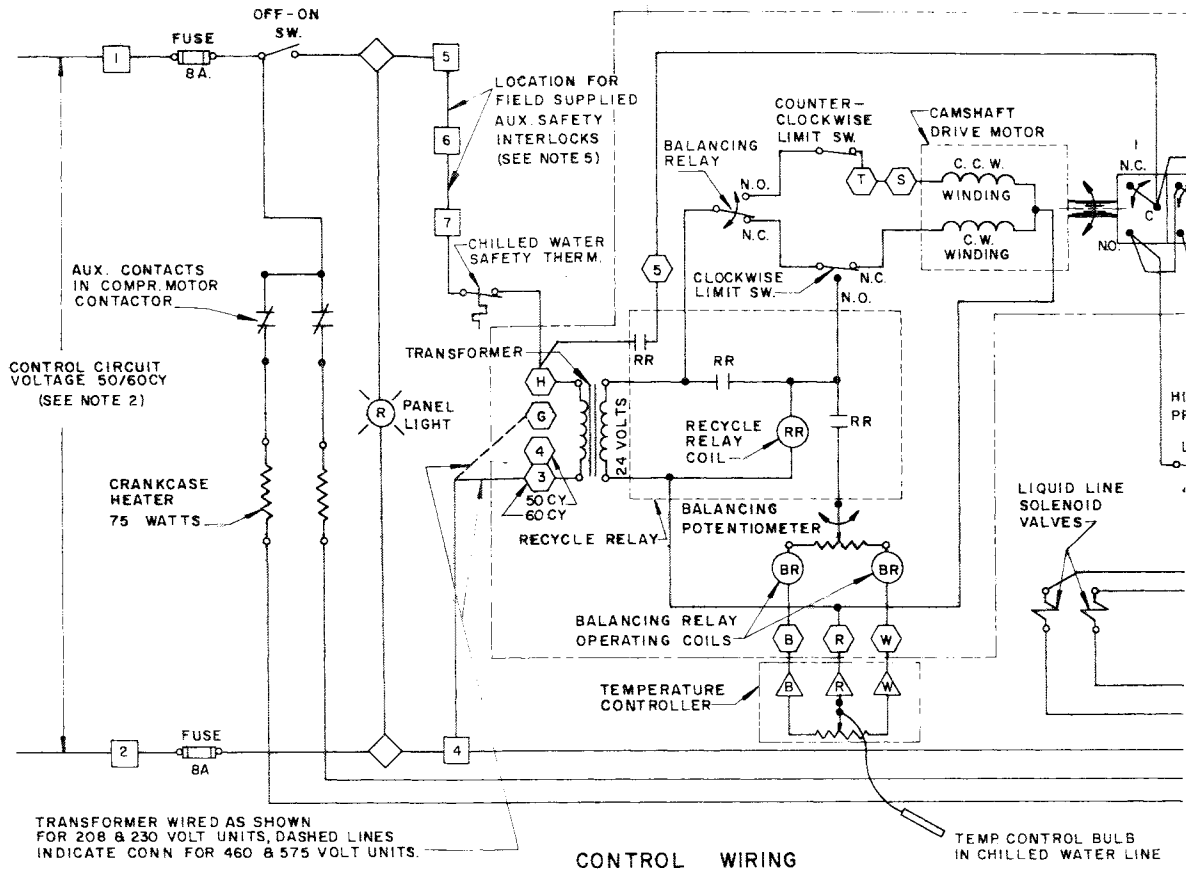
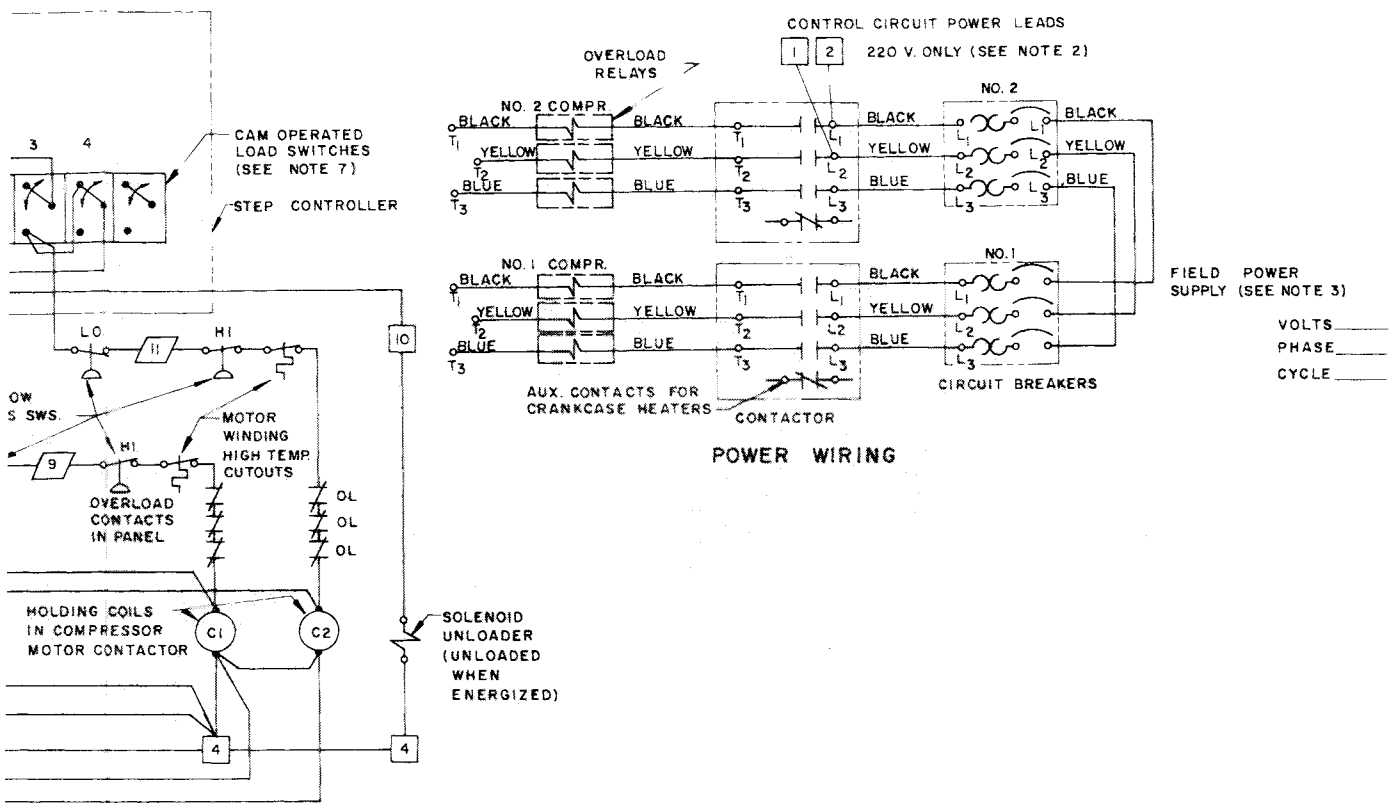

Fig. 36 - 30HH,HJ020, 025

WIRING



LEGEND

- TERMINALS ON MAIN TERMINAL STRIP
- ◇ TERMINALS ON PANEL LIGHT
- TERMINALS ON STEP CONTROLLER
- ▭ TERMINALS ON PRESS. SWITCH
- △ TERMINALS ON TEMPERATURE CONTROLLER

NOTES

1. ALL WIRING SHOWN IS FACTORY WIRING EXCEPT AS OUTLINED IN NOTE 2.
2. 208 VOLT & 230 UNITS HAVE 208/230 VOLT CONTROL CIRCUITS. ON THESE UNITS ONLY, LEADS ARE SUPPLIED FROM NUMBER 1 CONTACTOR TO TERMINALS 1 & 2 FOR THE PURPOSE OF ENERGIZING THE CONTROL CIRCUIT. 460 & 575 VOLT UNITS HAVE 115 VOLT CONTROL CIRCUITS, AND A SEPARATE 115 VOLT SOURCE MUST BE FIELD SUPPLIED THROUGH A FUSED DISCONNECT SWITCH TO TERMINALS 1 & 2.
3. FACTORY WIRING IS IN ACCORDANCE WITH THE NATIONAL ELECTRICAL CODE. ANY FIELD MODIFICATIONS OR ADDITIONS MUST BE IN COMPLIANCE WITH ALL APPLICABLE CODES.
4. CONTROL CIRCUIT FUSES MUST ALWAYS REMAIN IN THE CONTROL CIRCUIT. THE FUSES ARE 1/4" x 1 1/4" CERAMIC TUBE RATED AT 8 AMPS FOR 220 VOLT CIRCUITS AND 15 AMPS FOR 115 VOLT CIRCUITS.
5. MINIMUM SWITCH RATING FOR TERMINALS 5, 6 AND 7 AT 220 VOLTS IS 500 VOLT-AMPERES EACH. REMOVE JUMPERS AS REQUIRED FOR AUXILIARY INTERLOCKS.
6. MAXIMUM EXTERNAL CONTINUOUS LOADS TO BE CONNECTED BETWEEN TERMINALS 4 AND 9, AND TERMINALS 4 AND 5 ARE 250 VOLT-AMPERES EACH.
7. LOAD SWITCHES ARE SHOWN WITH UNIT FULLY UNLOADED, CAMSHAFT MOTOR RUNS C.C.W. (FROM POTENTIOMETER END) TO OPERATE LOAD SWITCHES 1 THRU 4 IN SEQUENCE AS CHILLED WATER TEMPERATURE INCREASES.
8. 250VA TRANSFORMER REQUIRED FOR DEVICES SHOWN ON CONTROL WIRING DIAGRAM. IF ADDITIONAL CONTROLS ARE USED, THE TRANSFORMER SIZE MUST BE INCREASED ACCORDINGLY.

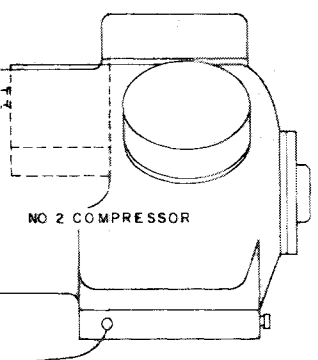
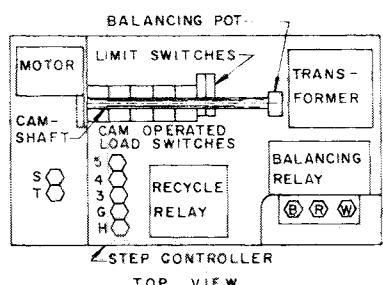

and 030 Wiring Diagram (Across-the-Line)

Dis. Reg. 30-20-57

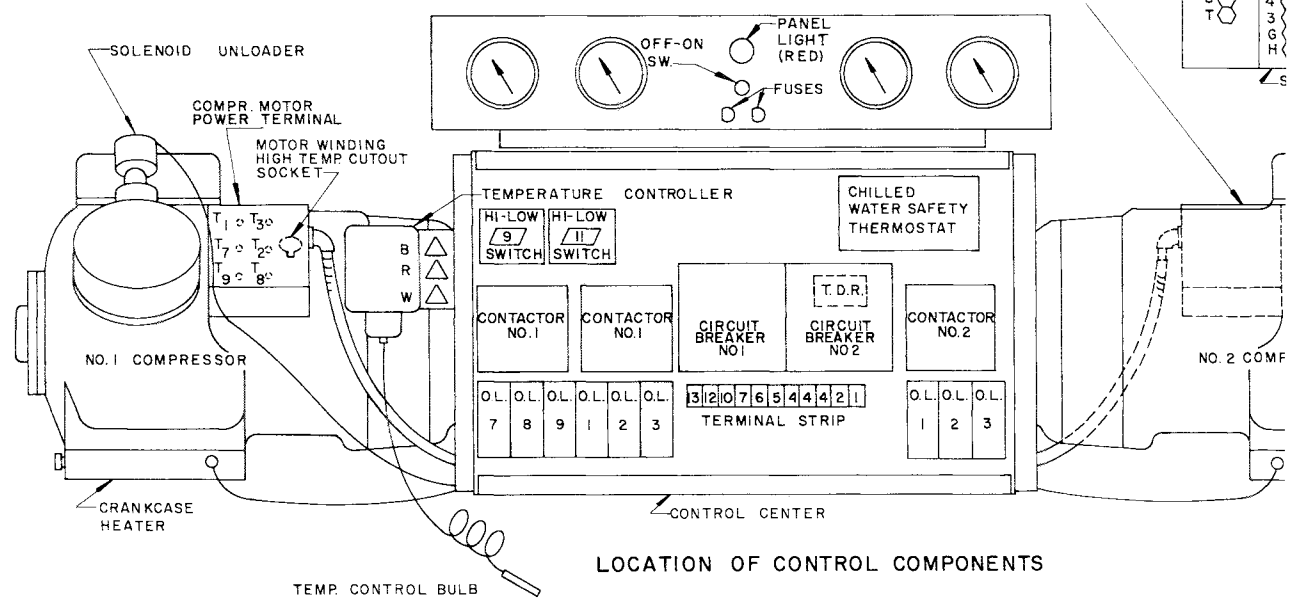
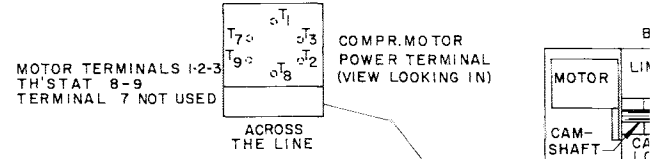
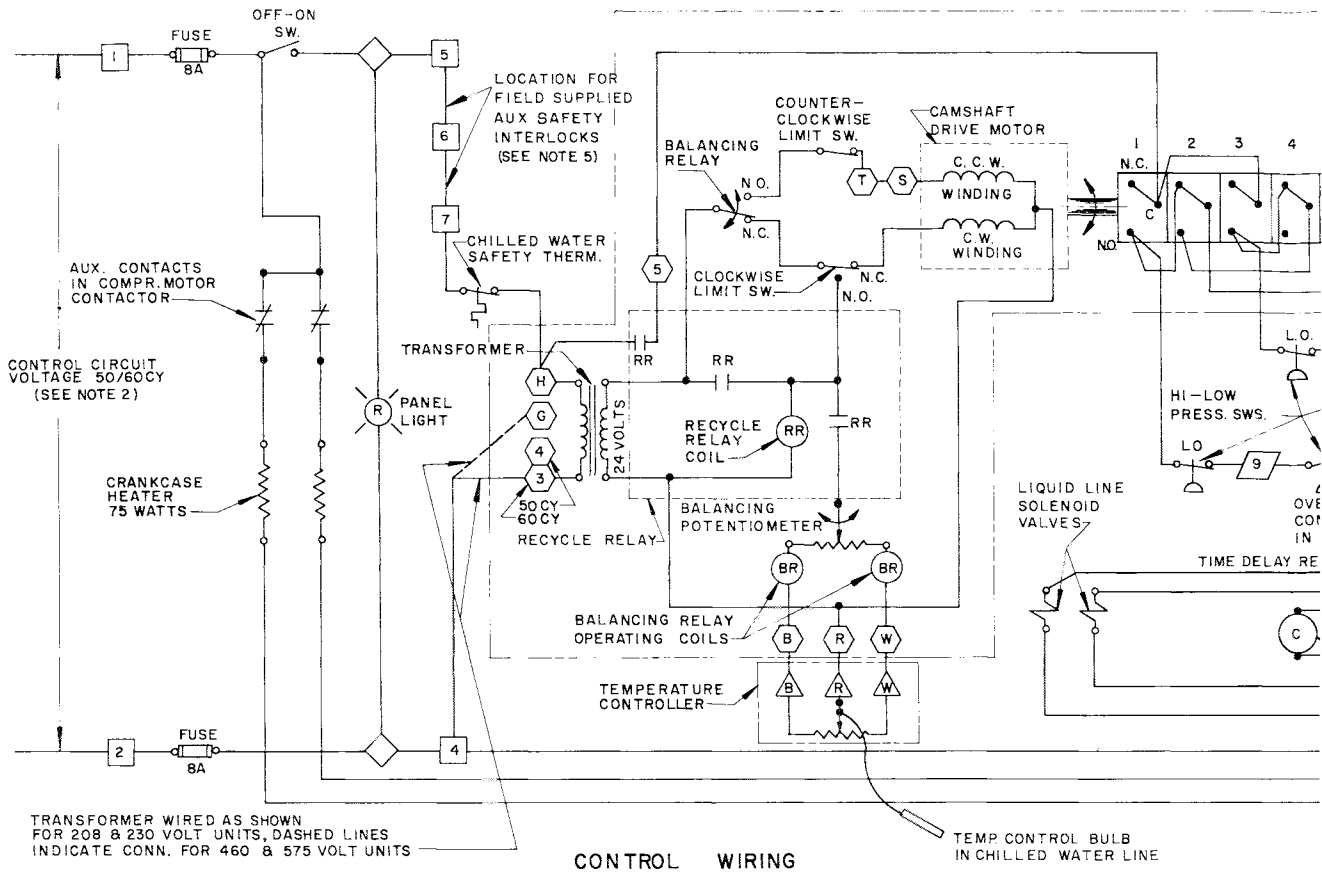
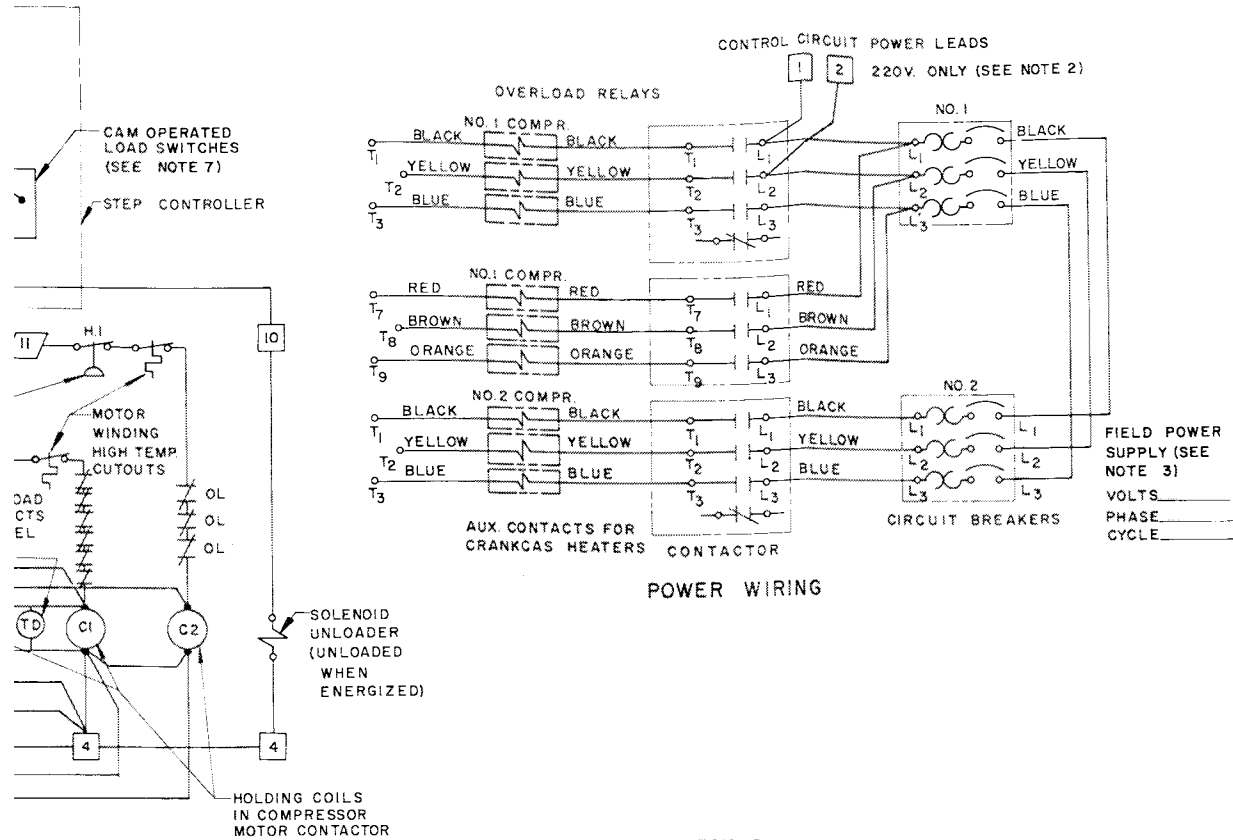

Fig. 37 - 30HH, HJ025 Wiring



LEGEND

- TERMINALS ON MAIN TERMINAL STRIP
- ◇ TERMINALS ON PANEL LIGHT
- TERMINALS ON STEP CONTROLLER
- ▭ TERMINALS ON PRESS. SWITCH
- △ TERMINALS ON TEMPERATURE CONTROLLER

NOTES

1. ALL WIRING SHOWN IS FACTORY WIRING EXCEPT AS OUTLINED IN NOTE 2.
2. 208 VOLT & 230 UNITS HAVE 208/230 VOLT CONTROL CIRCUITS. ON THESE UNITS ONLY, LEADS ARE SUPPLIED FROM NUMBER 1 CONTACTOR TO TERMINALS 1 & 2 FOR THE PURPOSE OF ENERGIZING THE CONTROL CIRCUIT. 460 & 575 VOLT UNITS HAVE 115 VOLT CONTROL CIRCUITS, AND A SEPARATE 115 VOLT SOURCE MUST BE FIELD SUPPLIED THROUGH A FUSED DISCONNECT SWITCH TO TERMINALS 1 & 2.
3. FACTORY WIRING IS IN ACCORDANCE WITH THE NATIONAL ELECTRICAL CODE. ANY FIELD MODIFICATIONS OR ADDITIONS MUST BE IN COMPLIANCE WITH ALL APPLICABLE CODES.
4. CONTROL CIRCUIT FUSES MUST ALWAYS REMAIN IN THE CONTROL CIRCUIT. THE FUSES ARE 1/4" x 1 1/4" CERAMIC TUBE RATED AT 8 AMPS. FOR 220 VOLT CIRCUITS AND 15 AMPS. FOR 115 VOLT CIRCUIT.
5. MINIMUM SWITCH RATING FOR TERMINALS 5, 6 AND 7 AT 220 VOLTS IS 500 VOLT-AMPERES EACH. REMOVE JUMPERS AS REQUIRED FOR AUXILIARY INTERLOCKS.
6. MAXIMUM EXTERNAL CONTINUOUS LOADS TO BE CONNECTED BETWEEN TERMINALS 4 AND 9, AND TERMINALS 4 AND 5 ARE 250 VOLT-AMPERES EACH.
7. LOAD SWITCHES ARE SHOWN WITH UNIT FULLY UNLOADED, CAMSHAFT MOTOR RUNS CCW. (FROM POTENTIOMETER END) TO OPERATE LOAD SWITCHES 1 THRU 4 IN SEQUENCE AS CHILLED WATER TEMPERATURE INCREASES.
8. 250VA TRANSFORMER REQUIRED FOR DEVICES SHOWN ON CONTROL WIRING DIAGRAM. IF ADDITIONAL CONTROLS ARE USED, THE TRANSFORMER SIZE MUST BE INCREASED ACCORDINGLY.

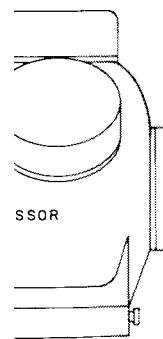
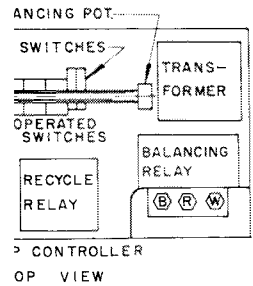

Diagram (Part Winding)

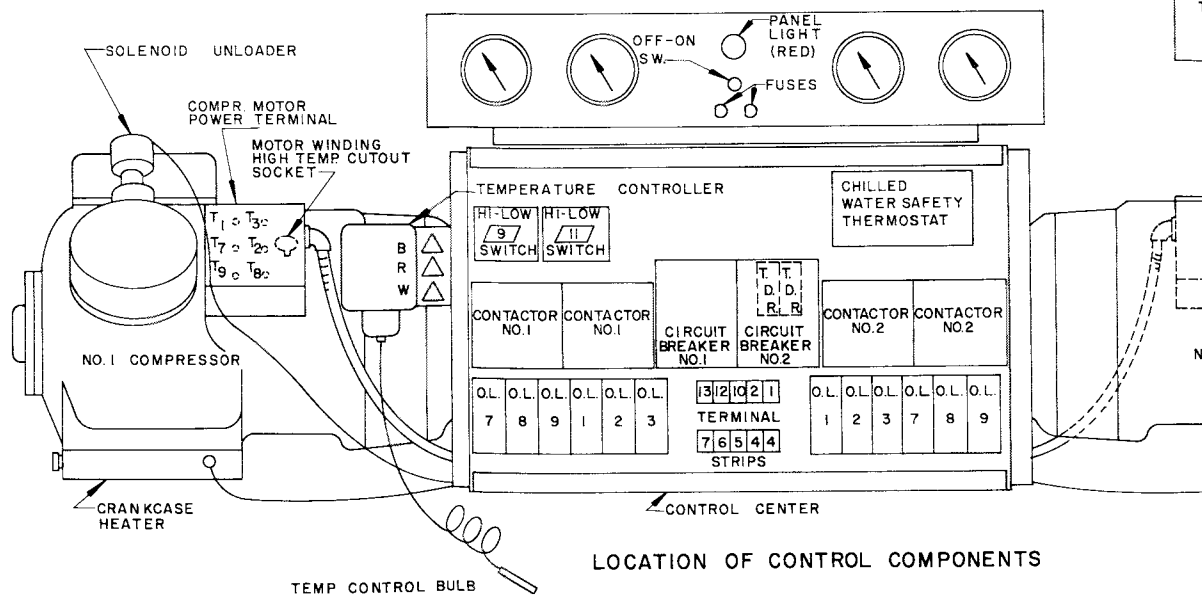
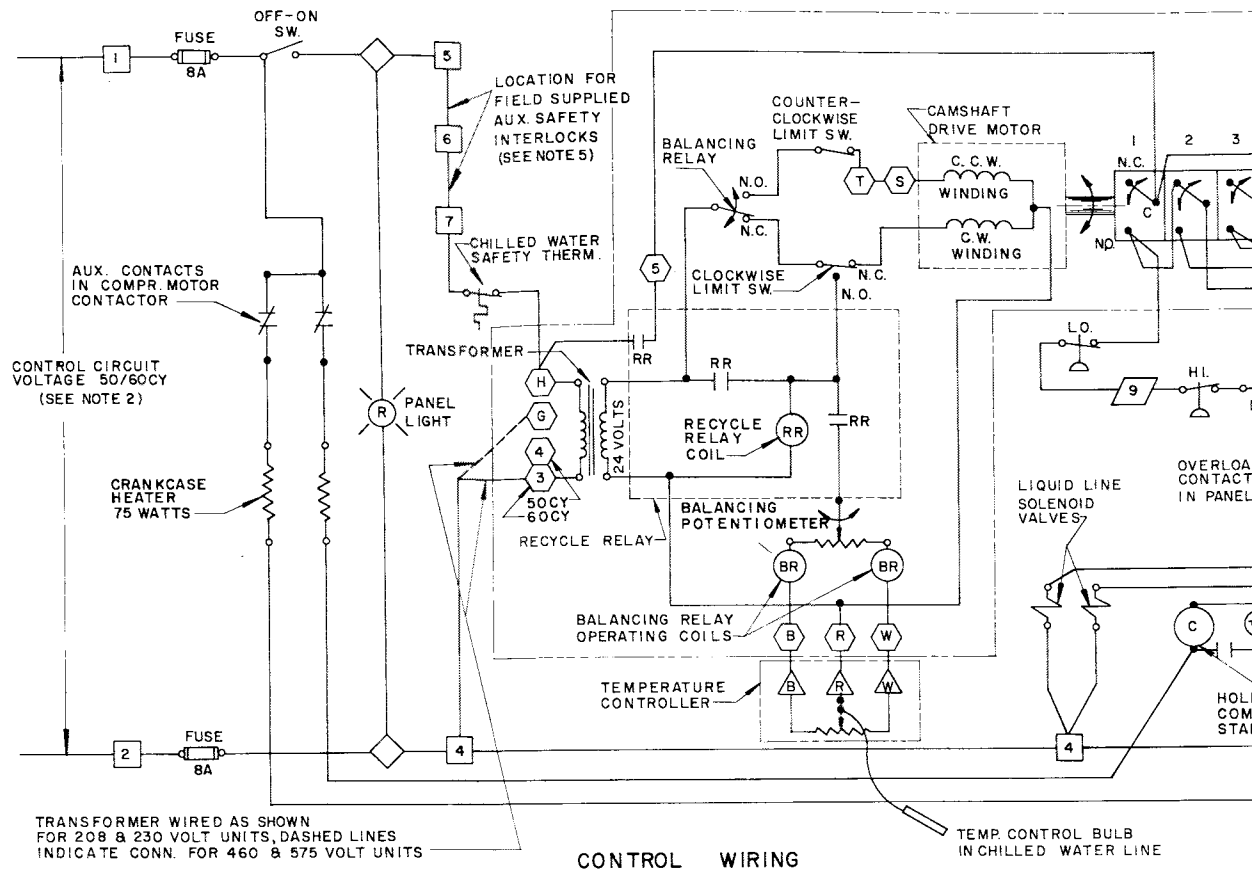
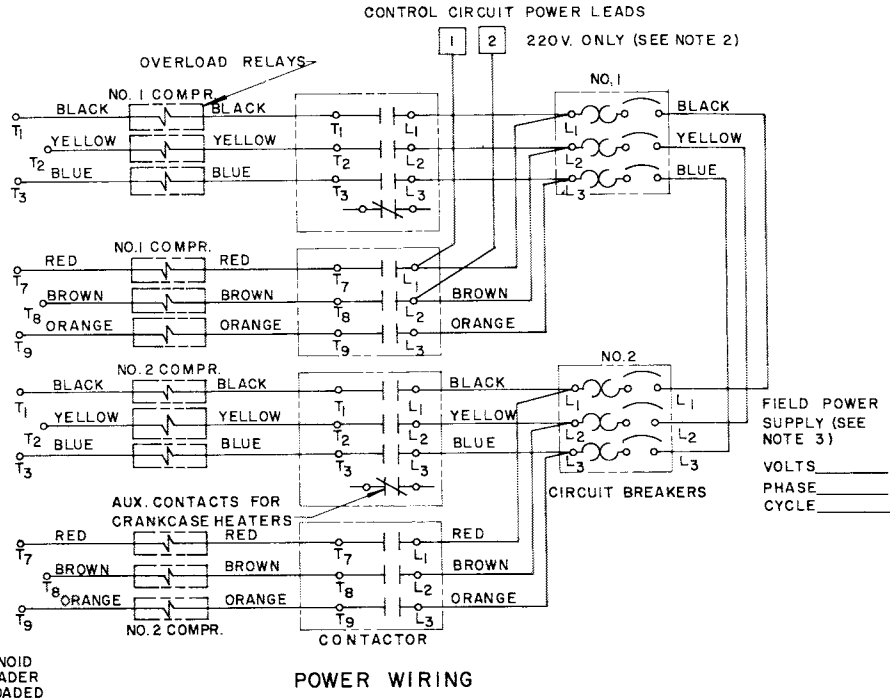
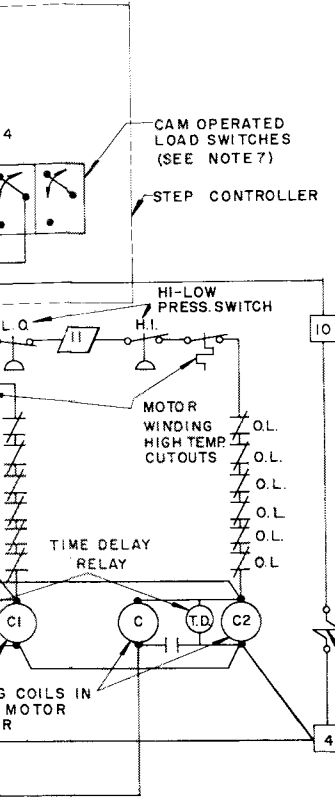

Fig. 38 - 30HH,HJ030

WIRING DIAGRAM



LEGEND

- TERMINALS ON MAIN TERMINAL STRIP
- ◇ TERMINALS ON PANEL LIGHT
- TERMINALS ON STEP CONTROLLER
- ▭ TERMINALS ON PRESS. SWITCH
- △ TERMINALS ON TEMPERATURE CONTROLLER

NOTES

1. ALL WIRING SHOWN IS FACTORY WIRING EXCEPT AS OUTLINED IN NOTE 2.
2. 208 VOLT & 230 UNITS HAVE 208/230 VOLT CONTROL CIRCUITS. ON THESE UNITS ONLY, LEADS ARE SUPPLIED FROM NUMBER 1 CONTACTOR TO TERMINALS 1 & 2 FOR THE PURPOSE OF ENERGIZING THE CONTROL CIRCUIT. 460 & 575 VOLT UNITS HAVE 115 VOLT CONTROL CIRCUITS, AND A SEPARATE 115 VOLT SOURCE MUST BE FIELD SUPPLIED THROUGH A FUSED DISCONNECT SWITCH TO TERMINALS 1 & 2.
3. FACTORY WIRING IS IN ACCORDANCE WITH THE NATIONAL ELECTRICAL CODE. ANY FIELD MODIFICATIONS OR ADDITIONS MUST BE IN COMPLIANCE WITH ALL APPLICABLE CODES.
4. CONTROL CIRCUIT FUSES MUST ALWAYS REMAIN IN THE CONTROL CIRCUIT. THE FUSES ARE 1/4" x 1 1/4" CERAMIC TUBE RATED AT 8 AMPS. FOR 220 VOLT CIRCUIT AND 15 AMPS. FOR 115 VOLT CIRCUITS.
5. MINIMUM SWITCH RATING FOR TERMINALS 5, 6 AND 7 AT 220 VOLTS IS 500 VOLT-AMPERES EACH. REMOVE JUMPERS AS REQUIRED FOR AUXILIARY INTERLOCKS.
6. MAXIMUM EXTERNAL CONTINUOUS LOADS TO BE CONNECTED BETWEEN TERMINALS 4 AND 9, AND TERMINALS 4 AND 5 ARE 250 VOLT-AMPERES EACH.
7. LOAD SWITCHES ARE SHOWN WITH UNIT FULLY UNLOADED. CAMSHAFT MOTOR RUNS C.C.W. (FROM POTENTIOMETER END) TO OPERATE LOAD SWITCHES 1 THRU 4 IN SEQUENCE AS CHILLED WATER TEMPERATURE INCREASES.
8. 250 VA TRANSFORMER REQUIRED FOR DEVICES SHOWN ON CONTROL WIRING DIAGRAM. IF ADDITIONAL CONTROLS ARE USED, THE TRANSFORMER SIZE MUST BE INCREASED ACCORDINGLY.

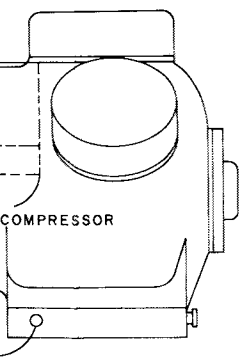
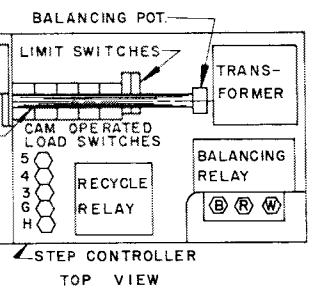

Wiring Diagram (Part Winding)

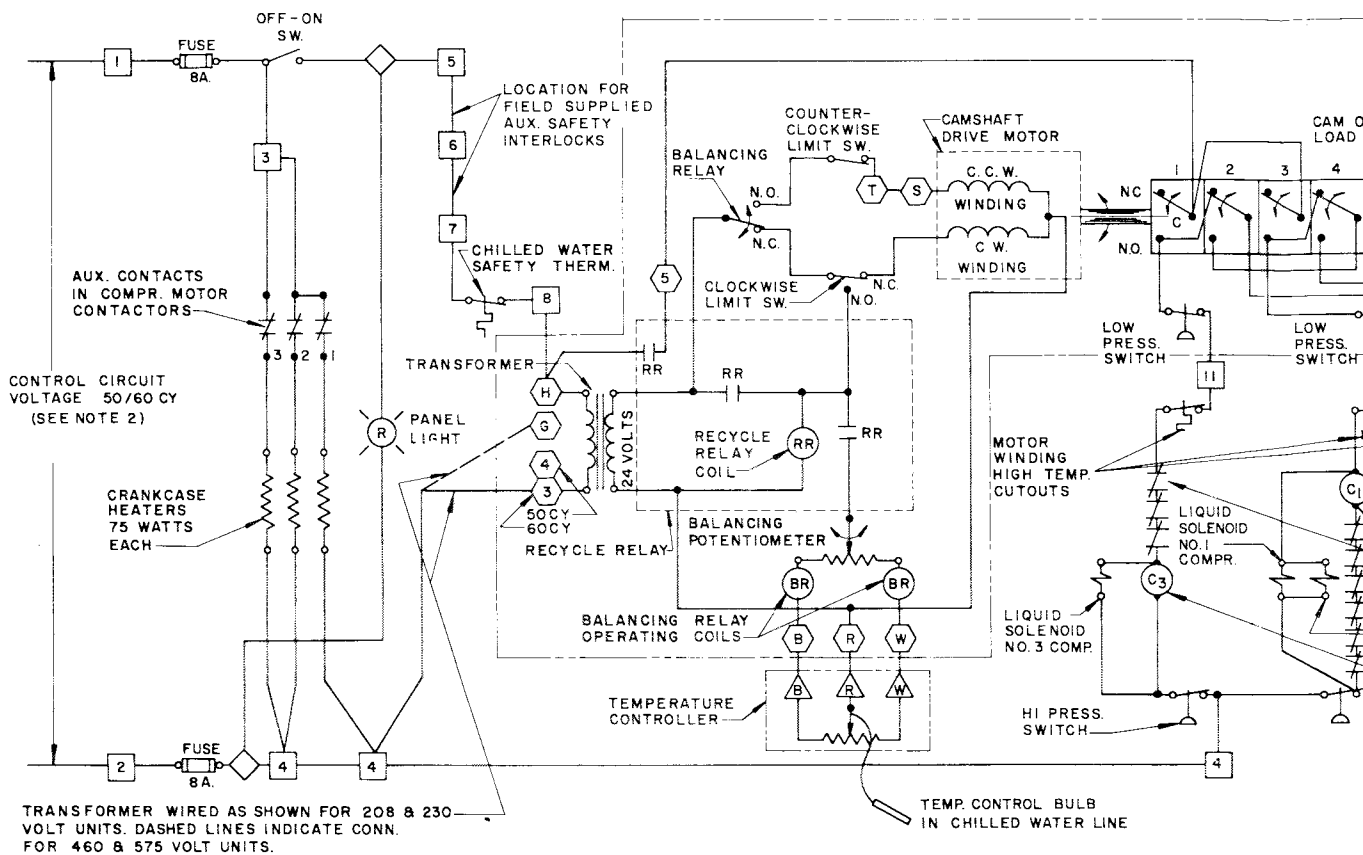

CONTROL WIRING

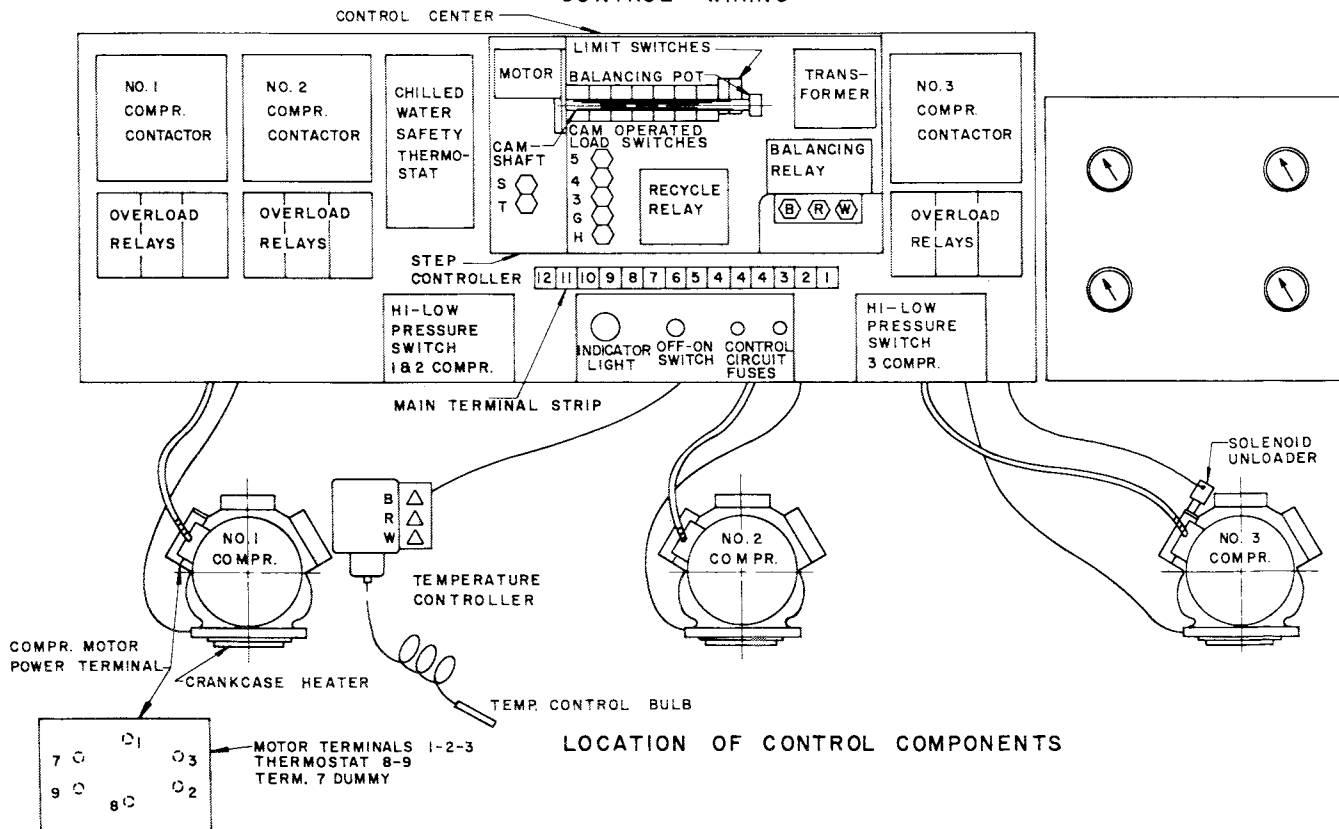
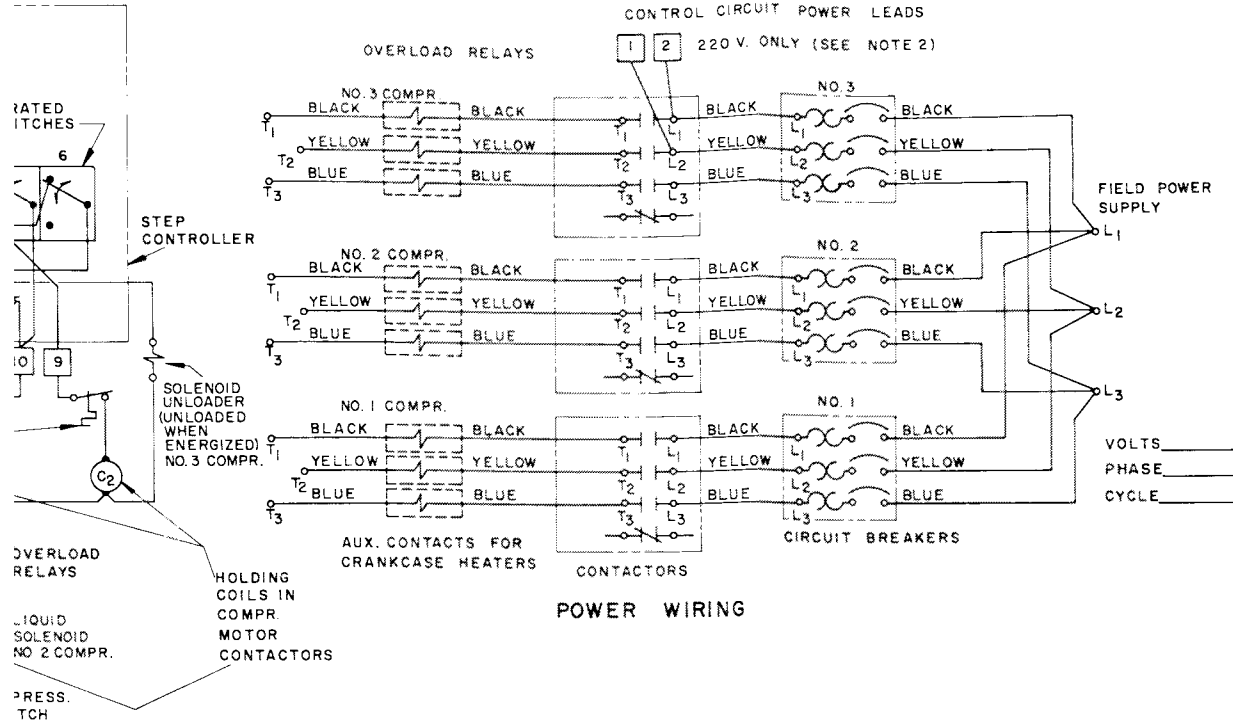

Fig. 39 - 30HH, HJ045 Wiring Diagram



LEGEND

- TERMINALS ON MAIN TERMINAL STRIP
- ◇ TERMINALS ON PANEL LIGHT
- TERMINALS ON STEP CONTROLLER
- △ TERMINALS ON TEMPERATURE CONTROLLER

NOTES

1. ALL WIRING SHOWN IS FACTORY WIRING EXCEPT AS OUTLINED IN NOTE 2.
2. 208 VOLT & 230 UNITS HAVE 208/230 VOLT CONTROL CIRCUITS. ON THESE UNITS ONLY, LEADS ARE SUPPLIED FROM NUMBER 3 CONTACTOR TO TERMINALS 1&2 FOR THE PURPOSE OF ENERGIZING THE CONTROL CIRCUIT. 460 & 575 VOLT UNITS HAVE 115 VOLT CONTROL CIRCUITS, AND A SEPARATE 115 VOLT SOURCE MUST BE FIELD SUPPLIED THROUGH A FUSED DISCONNECT SWITCH TO TERMINALS 1&2.
3. FACTORY WIRING IS IN ACCORDANCE WITH THE NATIONAL ELECTRICAL CODE. ANY FIELD MODIFICATIONS OR ADDITIONS MUST BE IN COMPLIANCE WITH ALL APPLICABLE CODES.
4. CONTROL CIRCUIT FUSES MUST ALWAYS REMAIN IN THE CONTROL CIRCUIT. THE FUSES ARE 1/4" x 1 1/4" CERAMIC TUBE RATED AT 8 AMPS. FOR 220VOLT CIRCUIT AND 15 AMPS. FOR 115 VOLT CIRCUITS.
5. MINIMUM SWITCH RATING FOR TERMINALS 5, 6 AND 7 AT 220 VOLTS IS 500 VOLT-AMPERES EACH. REMOVE JUMPERS AS REQUIRED FOR AUXILLARY INTERLOCKS.
6. MAXIMUM EXTERNAL CONTINUOUS LOADS TO BE CONNECTED BETWEEN TERMINALS 4 AND 9 AND TERMINALS 4 AND 5 ARE 250 VOLT AMPERES EACH.
7. LOAD SWITCHES ARE SHOWN WITH UNIT FULLY UNLOADED, CAMSHAFT MOTOR RUNS C.C.W. (FROM POTENTIOMETER END) TO OPERATE LOAD SWITCHES 1 THRU 6 IN SEQUENCE AS CHILLED WATER TEMPERATURE INCREASES.
8. 300 VA TRANSFORMER REQUIRED FOR DEVICES SHOWN ON CONTROL WIRING DIAGRAM. IF ADDITIONAL CONTROLS ARE USED, THE TRANSFORMER SIZE MUST BE INCREASED ACCORDINGLY.

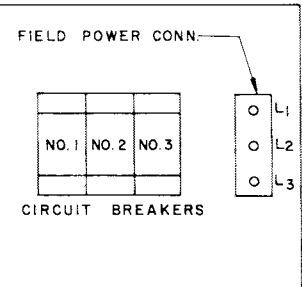

Dim. 30HH-055-86

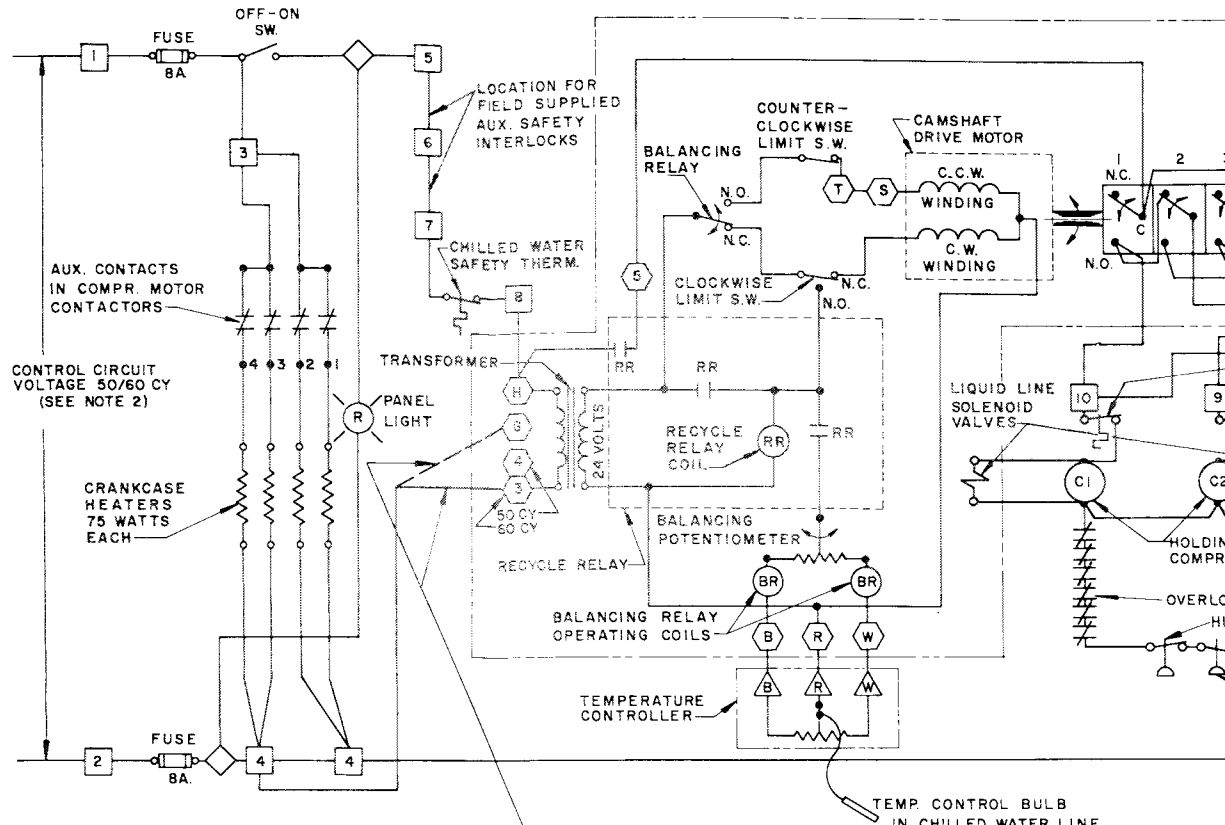

TRANSFORMER WIRED AS SHOWN FOR 208 & 230 VOLT UNITS. DASHED LINES INDICATE CONN FOR 460 & 575 VOLT UNITS.

CONTROL WIRING

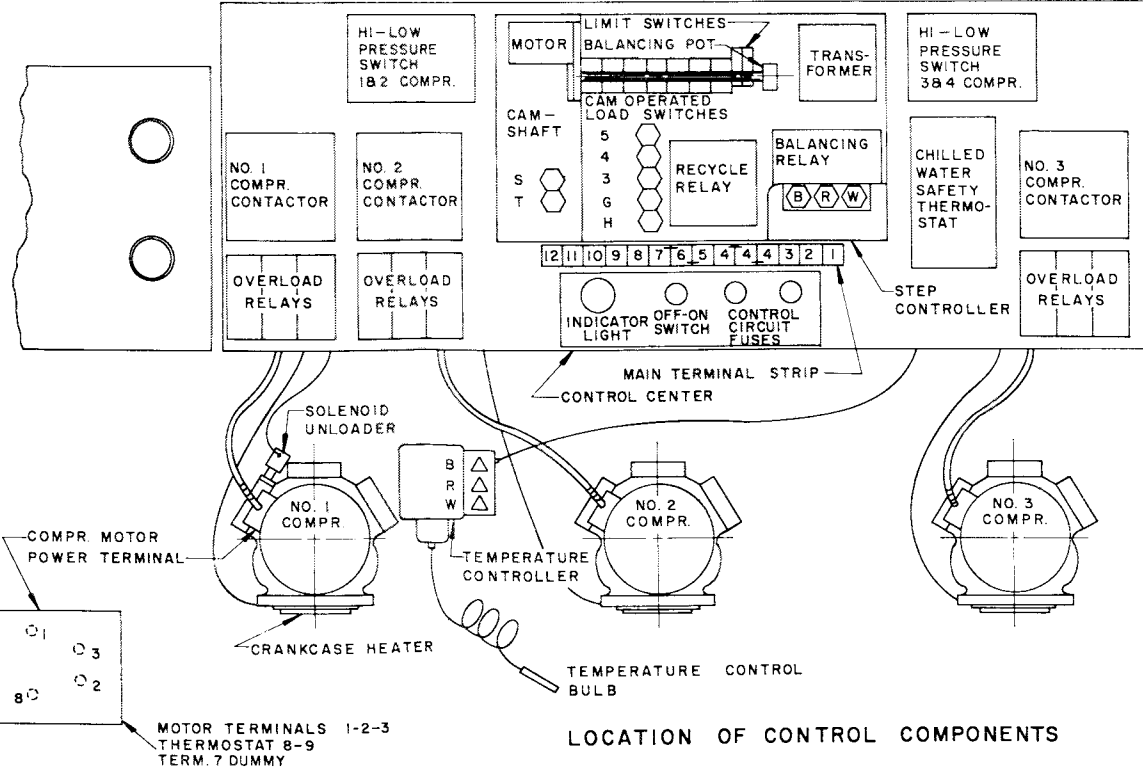

LOCATION OF CONTROL COMPONENTS

Fig. 40 - 30HH055 and 30H

WIRING DIAGRAM

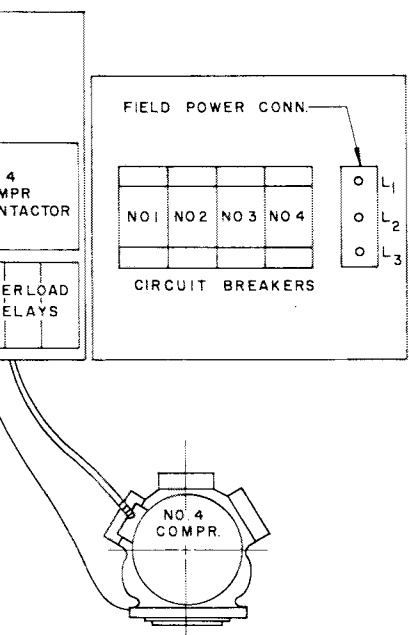
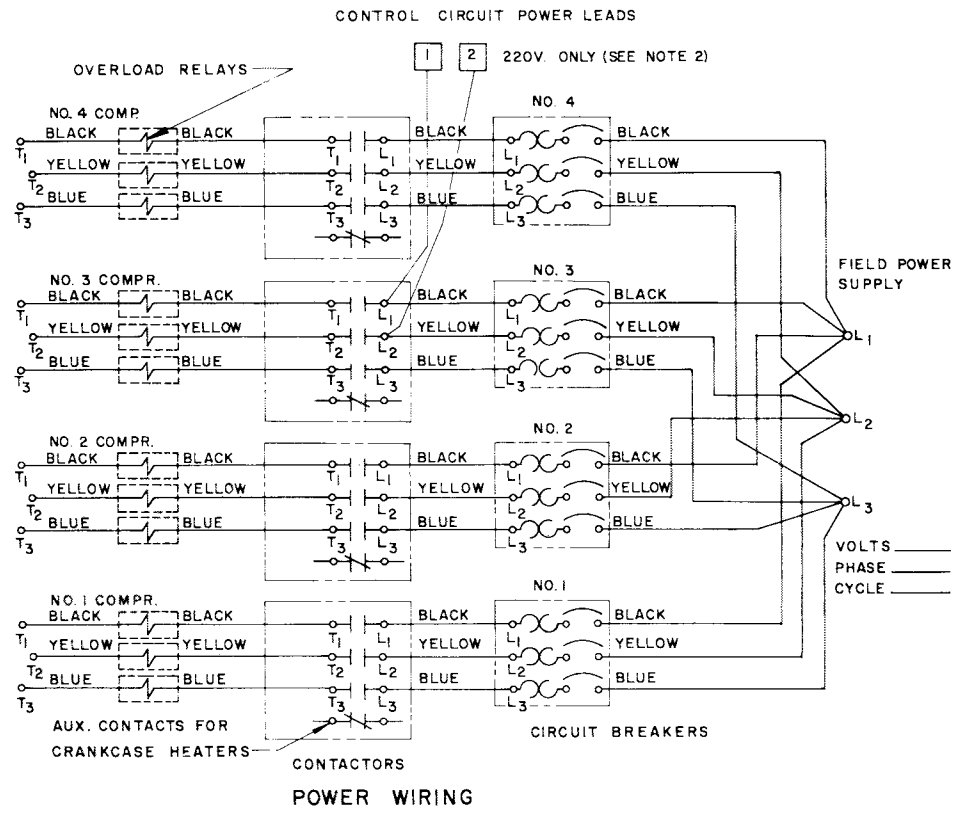
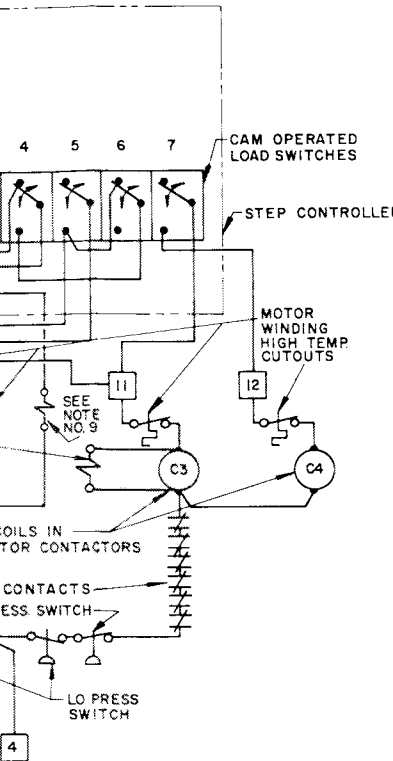

LEGEND

- TERMINALS ON MAIN TERMINAL STRIP
- ◇ TERMINALS ON PANEL LIGHT
- TERMINALS ON STEP CONTROLLER
- △ TERMINALS ON TEMPERATURE CONTROLLER

NOTES

1. ALL WIRING SHOWN IS FACTORY WIRING EXCEPT AS OUTLINED IN NOTE 2.
2. 208 VOLT & 230 V UNITS HAVE 208/230 VOLT CONTROL CIRCUITS, ON THESE UNITS ONLY, LEADS ARE SUPPLIED FROM NUMBER 3 CONTACTOR TO TERMINALS 1 & 2 FOR THE PURPOSE OF ENERGIZING THE CONTROL CIRCUIT. 460 & 575 VOLT UNITS HAVE 115 VOLT CONTROL CIRCUITS, AND A SEPARATE 115 VOLT SOURCE MUST BE FIELD SUPPLIED THROUGH A FUSED DISCONNECT SWITCH TO TERMINALS 1 & 2.
3. FACTORY WIRING IS IN ACCORDANCE WITH THE NATIONAL ELECTRICAL CODE. ANY FIELD MODIFICATIONS OR ADDITIONS MUST BE IN COMPLIANCE WITH ALL APPLICABLE CODES.
4. CONTROL CIRCUIT FUSES MUST ALWAYS REMAIN IN THE CONTROL CIRCUIT. THE FUSES ARE 1/4" x 1 1/4" CERAMIC TUBE RATED AT 8 AMPS. FOR 220 VOLT CIRCUIT AND 15 AMPS. FOR 115 VOLT CIRCUITS.
5. MINIMUM SWITCH RATING FOR TERMINALS 5, 6 AND 7 AT 220 VOLTS IS 500 VOLT-AMPERES EACH. REMOVE JUMPERS AS REQUIRED FOR AUXILIARY INTERLOCKS.
6. MAXIMUM EXTERNAL CONTINUOUS LOADS TO BE CONNECTED BETWEEN TERMINALS 4 AND 9, AND TERMINALS 4 AND 5 ARE 250 VOLT AMPERES EACH.
7. LOAD SWITCHES ARE SHOWN WITH UNIT FULLY UNLOADED, CAMSHAFT MOTOR RUNS C.C.W. (FROM POTENTIOMETER END) TO OPERATE LOAD SWITCHES 1 THRU 6 IN SEQUENCE AS CHILLED WATER TEMPERATURE INCREASES.
8. 375 VA TRANSFORMER REQUIRED FOR DEVICES SHOWN ON CONTROL WIRING DIAGRAM. IF ADDITIONAL CONTROLS ARE USED, THE TRANSFORMER SIZE MUST BE INCREASED ACCORDINGLY.
9. SOLENOID UNLOADER (UNLOADED WHEN ENERGIZED) NO. 1 COMPRESSOR.



INSTALLATION

30HH, HJ

Table 11 - Electrical Data

3-PHASE, 60 CYCLE, ACROSS-THE-LINE (XL) START EXCEPT AS INDICATED BY (†)									
30HH 30HJ	NO. OF COMPR SIZE	VOLTS- 30HH, 30HJ	TOTAL AMPS*						MAX KW
			Full Load		Locked† Rotor		Overload Trip		
015	1-6D73	208	49.3†	54.3†	191	266	69.0	76.0	16.0
		230	46.5	51.5†	172	240	65.0	72.0	
	1-6D75	460	23.2	25.7	86	120	32.5	36.0	19.0
		575	18.6	20.7	69	96	26.0	28.9	
020	2-6D68	208	54.4	67.2	340	340	76.0	94.0	19.8
		230	50.4	65.0	306	306	70.6	91.0	
	2-6D68	460	25.4	32.4	154	154	35.4	45.4	23.0
		575	20.4	26.0	124	124	28.4	36.4	
025	1-6D73	208†	76.5	87.9	361	436	107.0	123.0	25.9
	1-6D68	230†	71.7	84.0	325	393	100.3	117.5	
	1-6D75	460	35.9	41.9	163	197	50.2	58.7	30.5
		1-6D68	575	28.8	33.7	131	158	40.2	
030	2-6D73	208†	98.6	108.6	382	532	138.0	152.0	32.0
		230†	93.0	103.0	344	480	130.0	144.0	
	2-6D75	460	46.4	51.4	172	240	65.0	72.0	38.0
		575	37.2	41.4	138	192	52.0	57.8	
045	3-6D73	208	147.9	162.9	573	798	207.0	228.0	48.0
		230	139.5	154.5	516	720	195.0	216.0	
	3-6D75	460	69.6	77.1	258	360	97.5	108.0	57.0
		575	55.8	62.1	207	288	78.0	86.7	
055	3-6D73	208	175.1	-	743	-	245.0	-	57.9
		230	164.7	-	669	-	230.3	-	
	1-6D68	460	82.3	-	335	-	115.2	-	-
		575	66.0	-	269	-	92.2	-	
065	4-6D73	208	197.2	217.2	764	1064	276.0	304.0	64.0
		230	186.0	206.0	688	960	260.0	288.0	
	4-6D75	460	92.8	102.8	344	480	130.0	144.0	76.0
		575	74.4	82.8	276	384	104.0	115.6	
3 PHASE, 50 CYCLE, ACROSS-THE-LINE (XL) START EXCEPT AS INDICATED BY (†)									
015	1-6D73	230†	38.6	42.9	143	200	54.0	60.0	13.3
	1-6D75	400	23.2	25.7	83	115	32.5	36.0	
020	2-6D68	230	42.8	54.4	256	256	60.0	76.0	16.6
		400	25.4	32.4	148	148	35.4	45.4	
025	1-6D73	230†	60.0	71.1	271	328	84.0	98.0	21.6
	1-6D68	400	35.9	41.9	157	189	50.2	58.7	
	1-6D75	400	35.9	41.9	157	189	50.2	58.7	25.4
		1-6D68	400	35.9	41.9	157	189	50.2	
030	2-6D73	230†	77.2	85.8	286	400	108.0	120.0	26.6
		400	46.4	51.4	166	230	65.0	72.0	
045	3-6D73	230	115.8	128.7	429	600	162.0	180.0	39.9
		400	69.6	77.1	249	345	97.5	108.0	
055	3-6D73	230	137.2	-	557	-	145.8	-	48.2
		400	82.3	-	323	-	115.2	-	
065	4-6D73	230	154.4	171.6	572	800	216.0	240.0	53.2
		400	92.8	102.8	332	460	130.0	144.0	

*6D73, 6D75 single compressor ratings as shown for 30HH, HJ-015. For 6D68 compressor full load, locked rotor and overload trip amps divide 30HH, HJ020 Total Amp ratings by 2.

†Partial winding (PW) or across-the-line (XL) start.

‡Locked rotor amps indicate inrush result if all compressors were started instantaneously across-the-line. Step controller provides staggered starting.

NOTE: Control Circuit Voltage is 115 volts on 460 and 575 volt units, all others are 230 volts.

Overload trip amps vary because of vendor ratings. Full load amps vary because they are calculated from overload trip amp ratings.



ELECTRICAL DATA

The 6D73 and 6D75 compressors (30HH,HJ - 015, 025, 030 models) for 220 volt, 50 cycle application are supplied with six lead, part winding motors and extra starters to provide part winding start. This is available for the same 60 cycle units on special order.

Time delay relays are required for part winding starting.

Staggered starting of multiple compressors is insured by the step controller camshaft drive motor and recycle relay. Time delay relays are not required.

Volts - 3 Phase 60 Cycle	Normal Network Voltage Application Range	Voltage Limits for Satisfactory Operation
208	208	187 to 229
230	220 to 240	198 to 264
460	440 to 480	396 to 528
575	550 to 600	495 to 660

CAPACITY CONTROLS

The 30HH,HJ units are supplied with capacity controls which cycle compressors and load and unload cylinders of one compressor to give capacity control steps shown in Table 12 below.

The capacity controls supplied with each unit consists of a step controller, a solenoid-operated cylinder unloading device (two unloaders on 30HH015 and 30HJ015 units) and a chilled water temperature controller.

Step Controller - The step controller includes a small, low voltage motor with clockwise and counter-clockwise rotation windings that drive a camshaft. The factory-set cams operate load switches which start or stop compressors and load or unload cylinders. The motor windings of the camshaft drive motor are energized by a balancing relay which contains windings in the temperature bridge circuit between the chilled water temperature controller and the motor balancing potentiometer located at the end of the camshaft. When the unit is loading or unloading (counter-clockwise or clockwise rotation of the camshaft drive motor), one chilled water temperature corresponds to one position of the camshaft. Camshaft rotation is limited in each direction by limit switches.

The step controller also includes a recycle relay which insures that the camshaft is fully recycled to the unload position at startup or after a power interruption. After the camshaft has recycled to the unload position, the chilled water temperature controller takes control and starts camshaft rotation in the load direction which starts the compressors in sequence, insuring staggered compressor starting in every case.

While the unit is operating, the factory cam settings on the step controller protect the compressors against rapid cycling.

A small transformer is provided in the step controller which supplies 24 volt power to the camshaft drive motor.

Cylinder Unloading Device - On the 30HH,HJ020 thru 30HH,HJ065 units a single cylinder unloading device is installed on the lead compressor. The lead compressor is the farthest to the left when facing the front of the package, except 30HH,HJ045 units, where the lead compressor

Table 12 - Capacity Control Steps

Model Size	30HH,HJ 015	30HH,HJ 020, 025, 030	30HH,HJ 045	30HH055 30HH,HJ065
Compressors	1	2	3	4
Cylinder Unloading Devices	2	1	1	1
Capacity Control Steps	3	4	6	7
Active Cylinders Per Step	2, 4, 6	4, 6, 10, 12	4, 6, 10, 12, 16, 18	4, 6, 10, 12, 16, 18, 24
Approx. Percent Load Per Step	33, 67, 100	33, 50, 83, 100	22, 33, 55, 67, 89, 100	17, 25, 42, 50, 67, 75, 100

is the farthest to the right. The 30HH015 and 30HJ015 units are provided with two unloading devices on its single compressor. Each unloading device is the cylinder head bypass type and unloads two cylinders when the operating solenoid is energized. Cylinder unloaders are energized and de-energized by the cam operated load switches in the step controller.

Chilled Water Temperature Controller - The chilled water temperature controller supplied with each 30HH,HJ unit is the modulating remote bulb type with set point and throttling range adjustments. The remote bulb, field-inserted in the chilled water line, relays the chilled water temperature signal to the temperature controller potentiometer which actuates the step controller. To use the factory cam settings on the step controller, the remote bulb of the temperature controller must be inserted in the return chilled water line.

Control Bulb Location - It is generally required with all liquid chilling package applications that the leaving chilled water temperature be controlled. On liquid chilling packages where capacity can be controlled by a throttling device, the leaving chilled water temperature is usually controlled by placing the temperature control bulb in the leaving chilled water line. However, with any reciprocating liquid chilling package, where capacity is controlled by cylinder unloading or stopping and starting compressors, the reliability and accuracy of control of the leaving chilled water temperature are inherently better with the control bulb located in the return (entering) chilled water line. For this reason, the factory settings of the step controller cams on all 30HH,HJ units are based on control from the return (entering) chilled water temperature. If the unit is to be applied with the control bulb in the leaving chilled water line, the cams must be reset in the field. If this is required, contact the local Minneapolis-Honeywell representative.

The use of return chilled water control and factory cam settings on the step controller apply to systems designed for constant chilled water gpm thru the cooler.

SEQUENCE OF OPERATION

The sequence of control operation of the 30HH,HJ packages may be followed by referring to the control circuit diagram on the following page.

With power to the control circuit and the "OFF-ON" switch in the "OFF" position, the compressor crankcase heaters are energized. When the "OFF-ON" switch is put in the "ON" position, the panel light goes on and, with the chilled water safety thermostat and the field-supplied auxiliary interlocks satisfied, the low voltage transformer is energized. The recycle relay energizes the camshaft drive motor thru the balancing relay so that the camshaft is recycled to the no load position. When the unload direction limit is reached, the recycle relay puts power to the cam operated load switches and the temperature controller takes control. By recycling the controls at start-up or after a power interruption, staggered starting of multiple compressors is insured.

With the temperature controller in control the position of the camshaft is regulated according to the chilled water temperature. The cam operated load switches start or stop compressors and alternately load and unload cylinders of one compressor to control the capacity of the unit and balance it with the required load. During operation a change in temperature causes an unbalance in the temperature bridge circuit. This causes the balancing relay to energize the camshaft drive motor winding which turns the camshaft to increase or decrease the unit capacity as required.

All 30HH and HJ units are designed with Liquid Line Solenoid Drop. The liquid line solenoid in each refrigerant circuit is in parallel with the holding coil for the compressor in that circuit. The solenoid is energized when the compressor starts and the liquid line valve opens. When the compressor stops, the solenoid is de-energized and the valve closes. Where a refrigerant circuit has more than one compressor, the liquid line valve opens when the first compressor starts and closes when the last compressor stops.

The complete unit is stopped if the "OFF-ON" switch is put in the "OFF" position; if the chilled water safety thermostat contacts open; or if the contacts of any auxiliary interlock open. Individual compressors are stopped if the motor winding high temperature cutout contacts open or if the high or low pressure switch of the refrigerant circuit cuts out.

The compressor crankcase heater is turned on when the compressor is cycled off to prevent dilution and crankcase refrigerant condensation.

B30HH-5-1

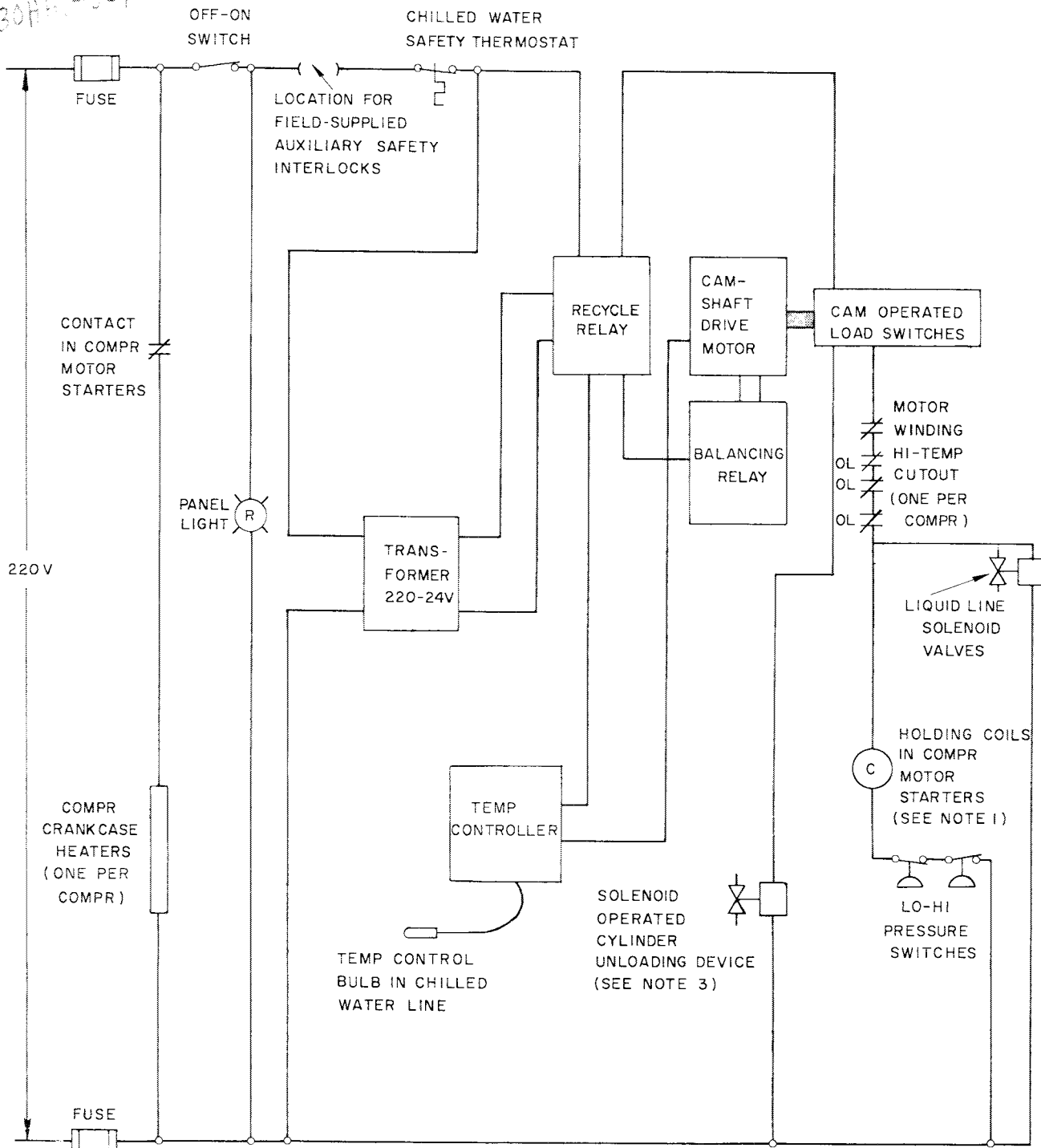

NOTES:

- The 30HH,HJ units have the following number of compressors:
 30HH,HJ015 - 1
 30HH,HJ020, 025, 030 - 2
 30HH,HJ045 - 3
 30HH1055, 30HH,HJ065 - 4
 On multiple compressor units the compressors are started in sequence from individual load switches.
- Liquid line solenoid valves are supplied one per refrigerant circuit on all models.
- The single compressor 30HH,HJ015 models are supplied with two cylinder unloading devices.
- Detailed reproducible wiring diagrams showing control wiring, power wiring and location of control components are available from Carrier offices.

Fig. 41 - Control Wiring Diagram

MOISTURE AND LIQUID INDICATOR

The moisture-liquid indicator serves two purposes. It shows that a sufficient charge of refrigerant is in the system when a clearflow of liquid refrigerant can be seen in the indicator. Bubbles in the flowing refrigerant indicate that the unit is undercharged or the presence of non-condensables.

The moisture-liquid indicator also provides a constant check on the moisture in the system.

The presence of moisture in the system, will be shown by a change of color of the indicator. The approximate moisture content is measured in parts per million (PPM).

Color	PPM - Moisture
Green	Below 45
Chartreuse (Caution)	45-130
Yellow (Wet)	Above 130

At the first signs of moisture in the system, the filter-drier should be changed.

IMPORTANT: With the machine running, the indicating element must be in contact with the LIQUID refrigerant to give a true moisture indication.

On units shipped from the factory with a holding charge only, the moisture-liquid indicator will be in contact with vapor only. Under these conditions the element may be in any one of three colors and will not indicate the true moisture content. A chartreuse or yellow color under these conditions does not indicate that the system is wet. To determine the actual moisture condition, the system should be running and completely charged.

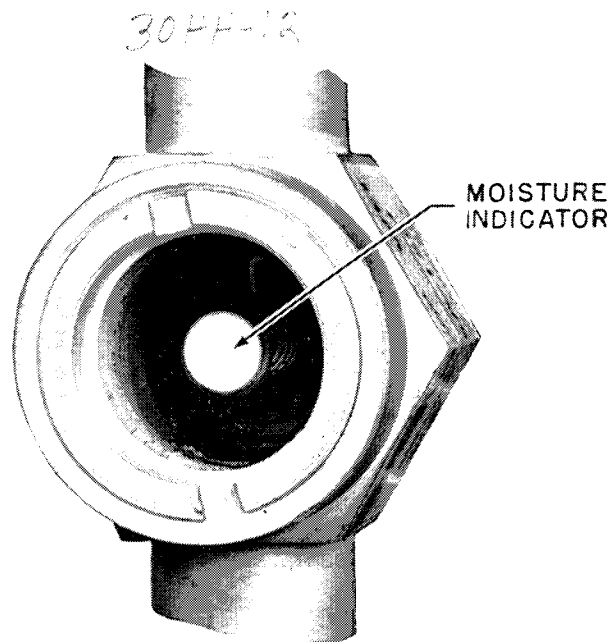

Fig. 42 - Moisture-Liquid Indicator

CONDENSER MAINTENANCE

Effect of Condenser on Head Pressure

The normal head pressure for an installation is determined when the job is engineered. Too great a variation from normal may be caused by:

1. Incorrect adjustment of the water regulating valve. (See Water Regulating Valve - Check Controls.)
2. Noncondensable gases.
3. Incorrect refrigerant charge.
4. Scaled condenser tubes.

How to Purge Noncondensable Gases

Purge noncondensable gases thru the purge cock on top of the condenser or receiver.

Inspecting Shell and Tube Condensers

The shell and tube condensers used on 30HH055, 065 chillers can be inspected on the water side by removing the heads. It is not necessary to pump down. The necessary steps are as follows:

1. Shut off the machine.
2. Shut off condenser water supply and disconnect the inlet and outlet piping.
3. Backseat the angle valve connecting the water regulating valve capillary to the condenser and disconnect the tubing from the valve.
4. Remove the drain plugs from the bottoms of the heads and the vent plug from the top of the front head and drain the water.
5. Remove the head bolts and heads.

A "Micro-Baffle" pass partition gasket made of soft metal seals the water passes (Fig. 43). When replacing a damaged gasket be sure to get a new one in the correct position.

Cleaning Shell and Tube Condensers

To clean the tubes on 30HH055,065 chillers, use a special nylon brush (available from local Carrier Distributor) or a similar brush attached to a rod. If hard scale has formed, the coils should be cleaned chemically. Do not use brushes that will scrape and scratch the tubes.

66L-41

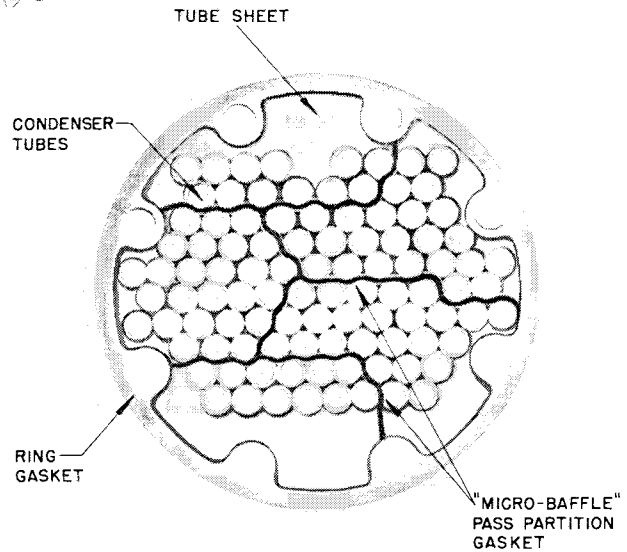

Fig. 43 - Location of Pass Partition (Typical)

Experience has shown that once the tubing has been scratched, corrosion takes place which results in pitting of the tubes. This is less likely to occur with chemical cleaning.

Flush water thru the coils while brushing. The results are best if the brush is turned with a slow speed electric drill.

It is also possible to clean the tubes by using air pressure to force rubber plugs thru the tubing.

After the tubes are cleaned, install the heads, connect the water lines, and flush the condenser to remove any remaining sediment.

Cleaning Shell and Coil Condenser

The simplest method of cleaning shell and coil condensers is with inhibited acid. Use an inhibited hydrochloric acid solution such as "Oakite 32." Handle the acid with the usual precautions because it will stain the hands and clothing and attack concrete. If the inhibitor is not present, it will attack steel. Where splashing may occur, cover the surfaces with burlap or boards. Gas coming from the vent pipe during cleaning is not harmful, but take care to prevent liquid from being carried over by the gas. The solution acts more readily if it is warm, but a cold solution and a longer time does just as thorough a job.

The Gravity Flow Method of Cleaning

The gravity flow method of cleaning is shown in Fig. 44. Do not add the solution more rapidly

than the vent can exhaust the gases generated by the chemical action. When the condenser is full, allow the solution to remain overnight. Drain the condenser and flush it with clean water.

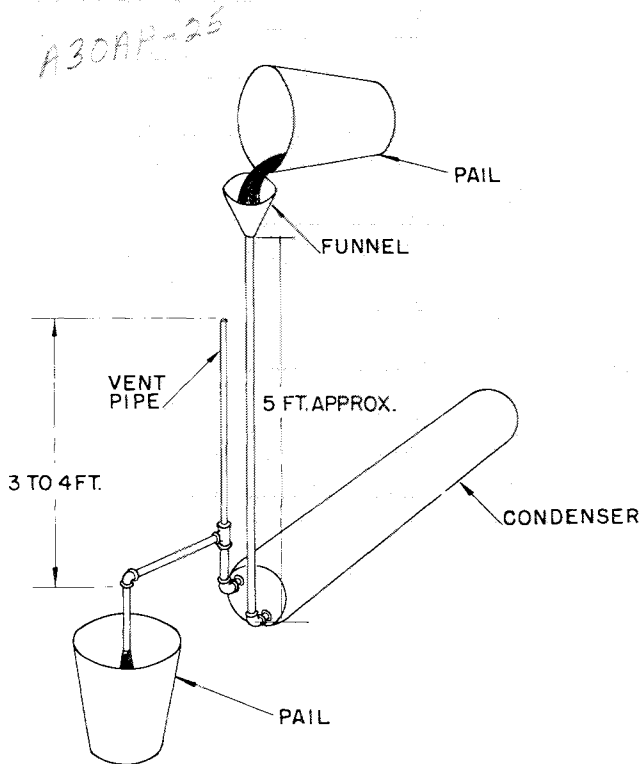

Fig. 44 - Gravity Circulation

The Forced Circulation Method of Cleaning

The forced circulation method of cleaning is shown in Fig. 45.

Fully open the vent pipe valve while the condenser is being filled with solution. It may be closed when the condenser is full and the pump is operating.

The valve in the supply line can be used to regulate the flow of solution to the condenser. If the pump is the nonoverloading type, the valve may be fully closed when the pump is running, should it be necessary.

For the average scale deposit, allow the solution to remain in the condenser overnight. For heavy deposits, allow twenty-four hours. Drain the condenser and flush it with clean water.

Repair

The shell and coil condensers are not easily repaired in the field and should be replaced in case of leakage. The shell and tube condensers are equipped with rolled in tubes. Tools are available for replacing the tubes in case of leakage.

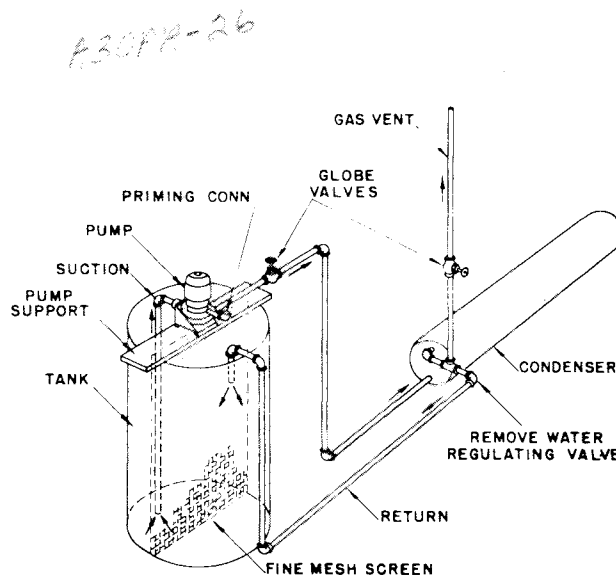

Fig. 45 - Forced Circulation

TROUBLE DIAGNOSIS CHART

SYMPTOMS	CAUSE	REMEDY	
A. Compressor does not run	Power line open	Reset circuit breaker	
	Control circuit fuse blown	Check control circuit for ground or short, repair and replace fuse	
	Safety thermostat tripped	Reset thermostat	
	Tripped starter overloads	See starters and overloads (check the controls)	
	Condenser circulating pump not running		Power off - restart
			Pump binding - free pump
			Incorrect wiring - rewire
			Pump motor burned out - replace
	Control stuck open	Replace control	
	Loose terminal connection	Check connections	
	Improperly wired controls	Check wiring and rewire	
	Low line voltage	Check line voltage - determine location of voltage drop	
Compressor motor effective	Check motor winding for open or short. Replace compressor, if necessary		
Seized compressor	Replace compressor		
B. Compressor cycles on low pressure control	Low pressure control erratic in action	Raise differential setting	
		Check capillary for pinches	
		Replace control	
	Compressor suction valve leaking	Replace valve plate	
	Compressor suction shut-off valve partially closed	Open valve	
	Low refrigerant charge	Add refrigerant	
Plugged compressor suction strainer	Clean strainer		
C. Compressor cycles on high pressure control	High pressure control erratic in action	Check capillary tube for pinches Set control as required	
	Compressor discharge valve partially closed	Open valve	
	Air in system	Purge	

SYMPTOMS	CAUSE	REMEDY
C. Compressor cycles on high pressure control (continued)	Condenser scaled	Clean condenser
	Receiver not properly vented - refrigerant backs up into evap. condenser	Repipe as required
	Condenser water pump not operating	Start pump
D. Unit operates long or continuously	Low refrigerant charge	Add refrigerant
	Control contacts fused	Replace control
	Air in system	Purge
	Partially plugged or plugged expansion valve or strainer	Clean or replace
	Defective insulation	Replace or repair
	Service load	Keep doors and windows closed
	Inefficient compressor	Check valves
E. System Noises	Piping Vibration	Support piping as required
		Check for loose pipe connectors
	Expansion valve hissing	Add refrigerant
		Check for plugged liquid line strainer
	Compressor noisy	Check valve plates for valve noise
		Replace compressor (worn bearings)
Check for loose compressor hold down bolts		
F. Compressor loses oil	Leak in system	Repair leak
	Plugged or stuck compressor snifter valve	Repair or replace
	Oil trapping in line	Check piping for oil traps
	Crankcase heaters not energized during shutdown	Replace heaters
G. Frosted or sweating suction line	Expansion valve admitting excess refrigerant	Adjust expansion valve
H. Hot liquid line	Shortage of refrigerant	Repair leak and recharge
	Expansion valve opens too wide	Adjust expansion valve



SYMPTOMS	CAUSE	REMEDY
I. Frosted liquid line	Receiver shut-off valve partially closed or restricted	Open valve or remove restriction
	Restricted catchall	Replace

COMPRESSOR MAINTENANCE

The 30HH and HJ Liquid Chillers use the Carrier 6D hermetic compressors. For detailed compres-

or operation and maintenance instructions, consult the 6D-Product Information Service Manual

CAUSE AND PREVENTION OF FREEZE-UP

CAUSE	PREVENTION
Improper charging.	<p>Make sure that a full quantity of water is flowing through the cooler while charging.</p> <p>Make sure the suction pressure in the cooler is equal to or greater than that corresponding to 32 F (58 psi for Refrigerant-22).</p>
Improperly set safety thermostat	Check the safety thermostat for proper setting at the beginning of each season.
Operating with safety thermostat bypassed.	The safety thermostat is wired in series with the compressor motor starter. Do not bypass it.
Improper chilled water circulation.	Use an ample sized cleanable strainer in the chilled water circuit. Make certain the strainer is clean to insure full flow and velocity of chilled water. It may sometimes be necessary to treat the water to prevent formation of deposits.
Not draining for winter shutdown.	When the system is shut down for the winter, remove the drain plugs and drain the cooler. Blow out any remaining water with air.

NOTES: 1. If the ambient temperature is below 32 F, freezing can be prevented by one of two methods:

- a. Drain all water from the equipment.
- b. Add antifreeze to the water.

A safe antifreeze that meets code and Underwriter requirements may be circulated with the residual water in the system. The antifreeze may be drained and re-used until it is diluted to the minimum safe limit.

2. Damage to chiller due to freezing is considered abuse and is not covered by the warranty.

